



Installer manual

NIBE F730

1x230 V

Exhaust air heat pump

IHB EN 1803-1
431702

Quick guide

Navigation

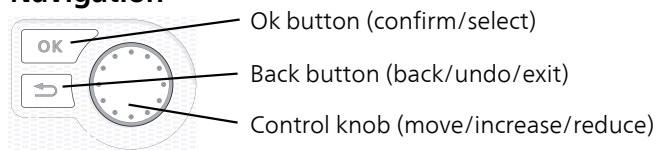

A detailed explanation of the button functions can be found on page 38.

How to scroll through menus and make different settings is described on page 40.

Set the indoor climate

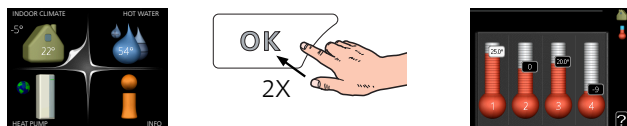

The mode for setting the indoor temperature is accessed by pressing the OK button twice, when in the start mode in the main menu.

Increase hot water volume



To temporarily increase the amount of hot water, first turn the control knob to mark menu 2 (water droplet) and then press the OK button twice.

Table of Contents

1 Important information	4	Menu system	39
Safety information	4		
General	5		
2 Delivery and handling	8	8 Control - Menus	42
Transport	8	Menu 1 - INDOOR CLIMATE	42
Assembly	8	Menu 2 - HOT WATER	42
Supplied components	9	Menu 3 - INFO	42
Removing the covers	10	Menu 4 - HEAT PUMP	43
Removing parts of the insulation	10	Menu 5 - SERVICE	44
3 The heat pump design	12	9 Service	50
Pipe connections	13	Maintenance	50
HVAC components	13	Service actions	51
Sensors etc.	13	10 Disturbances in comfort	54
Electrical components	13	Info-menu	54
Cooling components	13	Manage alarm	54
Ventilation	13	Troubleshooting	54
Miscellaneous	13	11 Accessories	56
4 Pipe and ventilation connections	14	12 Technical data	57
General pipe connections	14	Dimensions and setting-out coordinates	57
Dimensions and pipe connections	16	Technical specifications	59
Symbol key	17	Energy labelling	61
Cold and hot water	17	Electrical circuit diagram	63
Heating medium side	17	Item register	69
Installation alternative	18		
General ventilation connection	23		
Ventilation flow	23		
Adjusting ventilation	23		
Dimension and ventilation connections	23		
5 Electrical connections	24		
General	24		
Connections	26		
Settings	28		
Optional connections	29		
Connecting accessories	32		
6 Commissioning and adjusting	33		
Preparations	33		
Filling and venting	33		
Start-up and inspection	34		
Basic values for the curve setting	37		
7 Control - Introduction	38		
Display unit	38		

1 Important information

Safety information

This manual describes installation and service procedures for implementation by specialists.

The manual must be left with the customer.

This appliance can be used by children aged from 8 years and above and persons with reduced physical, sensory or mental capabilities or lack of experience and knowledge if they have been given supervision or instruction concerning use of the appliance in a safe way and understand the hazards involved. Children shall not play with the appliance. Cleaning and user maintenance shall not be made by children without supervision.

Rights to make any design or technical modifications are reserved.

©NIBE 2017.

Marking

CE The CE mark is obligatory for most products sold in the EU, regardless of where they are made.

IP21 Classification of enclosure of electro-technical equipment.



Read the User Manual.



Read the Installer Manual.

Symbols



NOTE

This symbol indicates danger to person or machine.



Caution

This symbol indicates important information about what you should observe when maintaining your installation.



TIP

This symbol indicates tips on how to facilitate using the product.

General

Serial number

The serial number can be found at the bottom right of the front cover and in the info menu (menu 3.1).

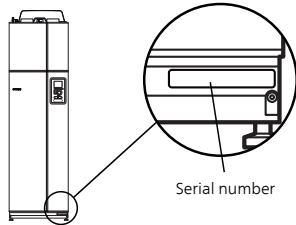

Caution

You need the product's (14 digit) serial number for servicing and support.

Recovery



Leave the disposal of the packaging to the installer who installed the product or to special waste stations.

Do not dispose of used products with normal household waste. It must be disposed of at a special waste station or dealer who provides this type of service.

Improper disposal of the product by the user results in administrative penalties in accordance with current legislation.

Environmental information

This unit contains a fluorinated greenhouse gas that is covered by the Kyoto agreement.

F-Gas Regulation (EU) No. 517/2014

The equipment contains R407C, a fluorinated greenhouse gas with a GWP value (Global Warming Potential) of 1774. Do not release R407C into the atmosphere.

Country specific information

United Kingdom

This installation is subject to building regulation approval, notify the local Authority of intention to install.

Use only manufacturer's recommended replacement parts.



Benchmark places responsibilities on both manufacturers and installers. The purpose is to ensure that customers are provided with the correct equipment for their needs, that it is installed, commissioned and serviced in accordance with the manufacturers instructions by competent persons and that it meets the requirements of the appropriate Building Regulations. The Benchmark Checklist

can be used to demonstrate compliance with Building Regulations and should be provided to the customer for future reference.

Installers are required to carry out the installation, commissioning and servicing work in accordance with the Benchmark Code of practice which is available from the Heating and Hotwater Industry Council who manage and promote the Scheme. Visit www.centralheating.co.uk for information.

Warranty and insurance information

Thank you for installing a new NIBE heat pump in your home.

NIBE heat pumps are manufactured in Sweden to the very highest standard so we are pleased to offer our customers a comprehensive guarantee.

The product is guaranteed for 24 months for parts and labour from the date of installation or 33 months from the date of manufacture, whichever is the shorter.

The NIBE guarantee is based on the unit being installed and commissioned by a NIBE accredited installer, serviced every year and the Benchmark documents completed. Where this condition is not met, any chargeable spare parts or components issued within the applicable guarantee period still benefit from a 12 month warranty from the date of issue by the manufacturer.

We recommend the installer completes and returns as soon as possible, your guarantee registration card or completes the guarantee form on the NIBE website www.nibe.co.uk.

Electrical Supply

The heat pump must be permanently connected to a 230V ac 50Hz supply.

All system components shall be of an approved type and all wiring to current I.E.E wiring regulations.

External wiring must be correctly earthed, polarised and in accordance with the relevant standards: Currently this is BS 7671.

Domestic Hot Water

All domestic hot water circuits, connections and fittings must be in accordance with the relevant standards and water supply regulations. It should also be in accordance with the relevant requirements of the Local Authority and the Building Regulations relevant to the location of installation.

BS 8558:2015 Services supplying water for domestic use within buildings and their cartilages.

Water Supply (Water Fitting) Regulations 1999 or The Water Bylaws 2000 (Scotland).

Heating System

The installation of the heat pump should follow best practice as covered in the following:

BS 5449 Forced circulation hot water central heating systems for domestic premises.

BS 15450 Heating systems in buildings – Design of heat pump heating systems.

Ventilation System

Any ventilation system should be designed and installed in accordance with Building Regulations, England & Wales Approved Document F1 and Scotland Technical Standard Section 3.14 Ventilation. Only this will ensure hygienic room air and prevent any dampness to the building structure.

To be able to ensure a high degree of efficiency and an extremely comfortable living environment, we recommend that the installation of any ventilation system should be planned and this plan be strictly followed by the ventilation engineer.

The discharge air duct work to outside must be insulated to ensure condensation does not form in the duct work.

Inspection of the installation

Current regulations require the heating installation to be inspected before it is commissioned. The inspection must be carried out by a suitably qualified person. In addition, fill in the page for the installation data in the User Manual.

✓	Description	Notes	Signature	Date
	Ventilation (page 23)			
	Outdoor air damper			
	Setting ventilation flow exhaust air			
	Setting the ventilation flow outdoor air			
	Heating medium (page 17)			
	System flushed			
	System vented			
	Safety valve			
	Pressure in the climate system			
	Cold water (page 17)			
	Expansion vessel			
	Hot water (page 17)			
	Safety valve			
	Expansion vessel			
	T&P valve			
	Tundish			
	Electricity (page 24)			
	Connections			
	Main voltage			
	Phase voltage			
	Fuses heat pump			
	Fuses property			
	Outside sensor			
	Room sensor			
	Safety breaker			
	Earth circuit-breaker			
	Miscellaneous			
	Benchmark checklist			

2 Delivery and handling

Transport

F730 is supplied in two sections and can be installed separately or as one unit. The images in this manual show F730 installed as one unit. For more information see page 18.

F730 should be transported and stored vertically in a dry place. However, the F730 may be carefully laid on its back when being moved into a building. The centre of gravity is in the upper part.

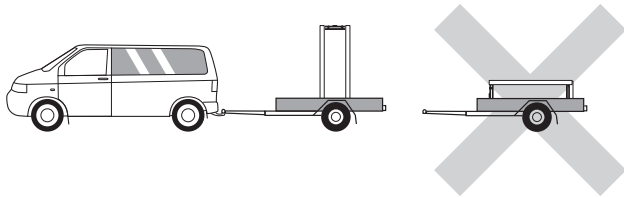

Assembly

- Position F730 on a fixed foundation that can take the weight of the heat pump. Use the product's adjustable feet to obtain a horizontal and stable set-up.

Because water comes from F730, the floor coating is important. A waterproof floor or floor membrane is recommended.

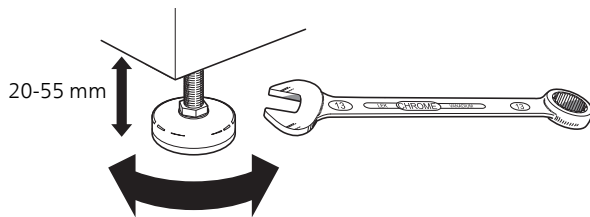

- Install with its back to an outside wall, ideally in a room where noise does not matter, in order to eliminate noise problems. If this is not possible, avoid placing it against a wall behind a bedroom or other room where noise may be a problem.
- Wherever the unit is located, walls to sound sensitive rooms should be fitted with sound insulation.
- Route pipes so they are not fixed to an internal wall that backs on to a bedroom or living room.
- The heat pump's installation area should always have a temperature of at least 10 °C and max 30 °C.

Installation area

Leave a free space of 800 mm in front of the product. Leave free space between F730 and wall/other machinery/fittings/cables/pipes etc. It is recommended that a space of at least 10 mm is left to reduce the risk of noise and of any vibrations being propagated.

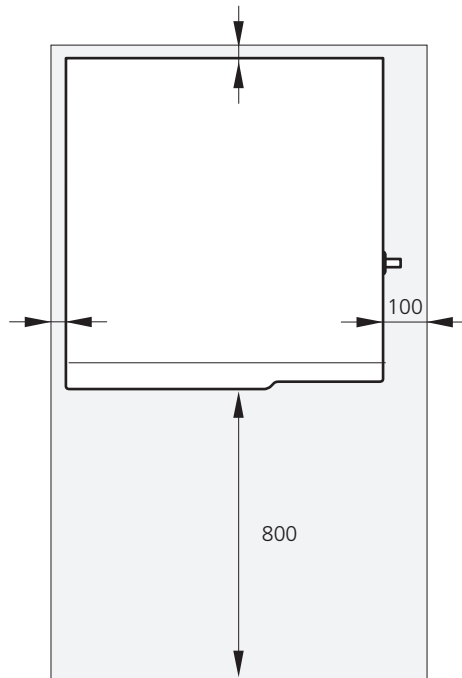

NOTE

Ensure that there is sufficient space (300 mm) above the heat pump for installing ventilation hoses.

Supplied components

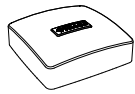

Outside sensor

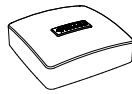

Room sensor

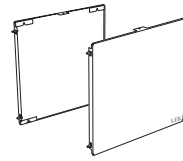

Side panels,
air treatment unit



Vent hose
(length 4 m)



Extra air filter

Location

The kit of supplied items is placed on top of the product.



2 x tundish



Gasket

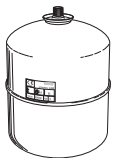

Expansion vessel with
holder
(supplied separately)

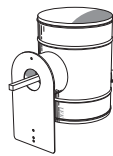

Outdoor air damper



Damper motor incl. 2
screws



Ambient sensor

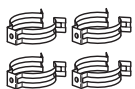

Clips



Screw



O-rings

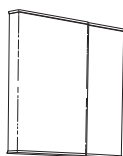

Front hatch,
air treatment section

Removing the covers

Front cover

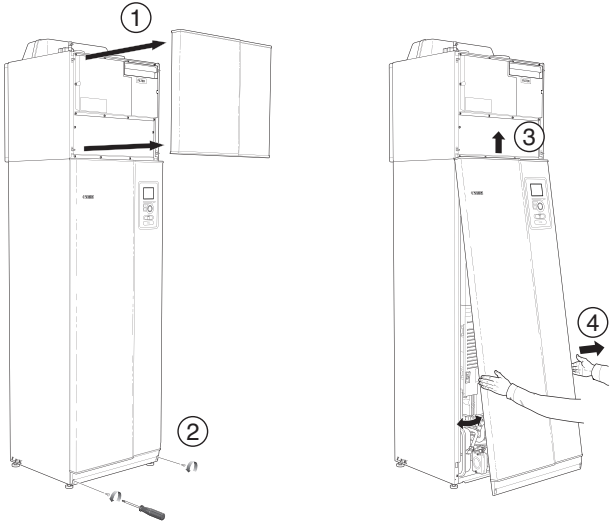

1. Remove the upper panel by pulling it straight out.
2. Remove the screws from the lower edge of the front panel.
3. Lift the panel out at the bottom edge and up.
4. Pull the panel towards yourself.

Side covers

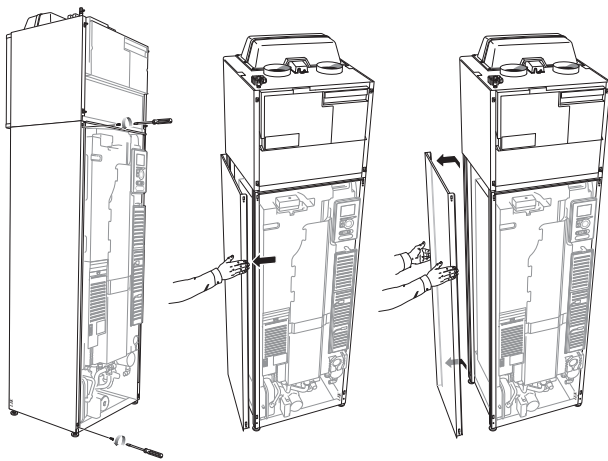

The side covers can be removed to facilitate the installation.

1. Remove the screws from the upper and lower edges.
2. Twist the cover slightly outward.
3. Move the hatch backwards and slightly to the side.
4. Pull the cover to one side.
5. Pull the hatch forwards.

Removing parts of the insulation

Parts of the insulation can be removed to facilitate the installation.

Insulation, top

1. Disconnect the cable from the motor and remove the motor from the shuttle valve as illustrated.

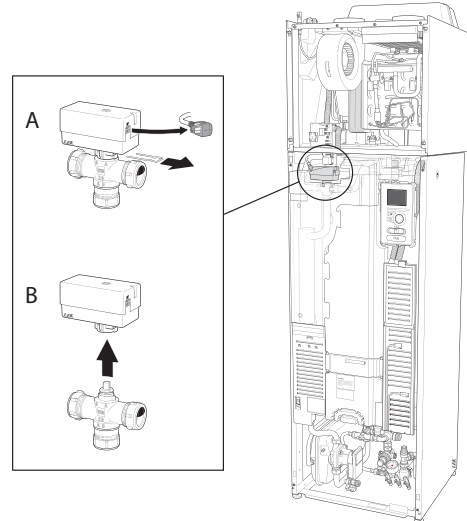

2. Grip the handle and pull straight out as illustrated.

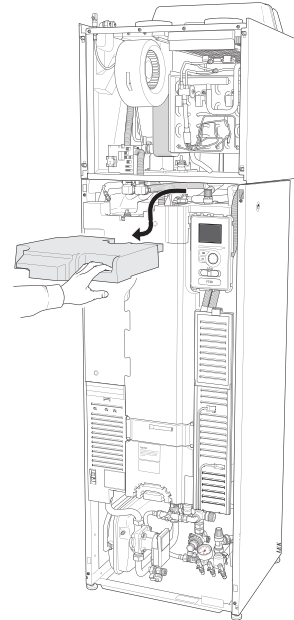

Insulation, immersion heater



NOTE

Electrical installation and service must be carried out under the supervision of a qualified electrician. Electrical installation and wiring must be carried out in accordance with the stipulations in force.

1. Remove the cover for the junction box according to the description on page 25.
2. Grip the handle and pull the insulation carefully towards you as illustrated.

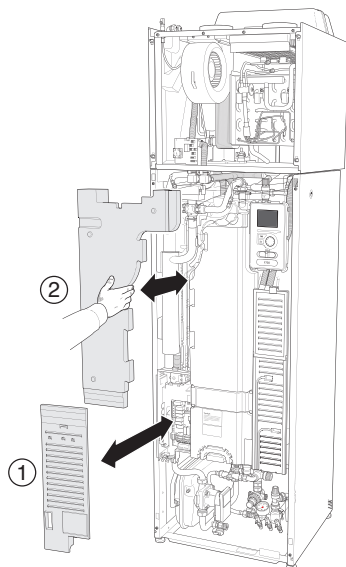

TIP

Remove the hatch for the immersion heater card so that it is easier to remove the insulation (see page 25).

3 The heat pump design

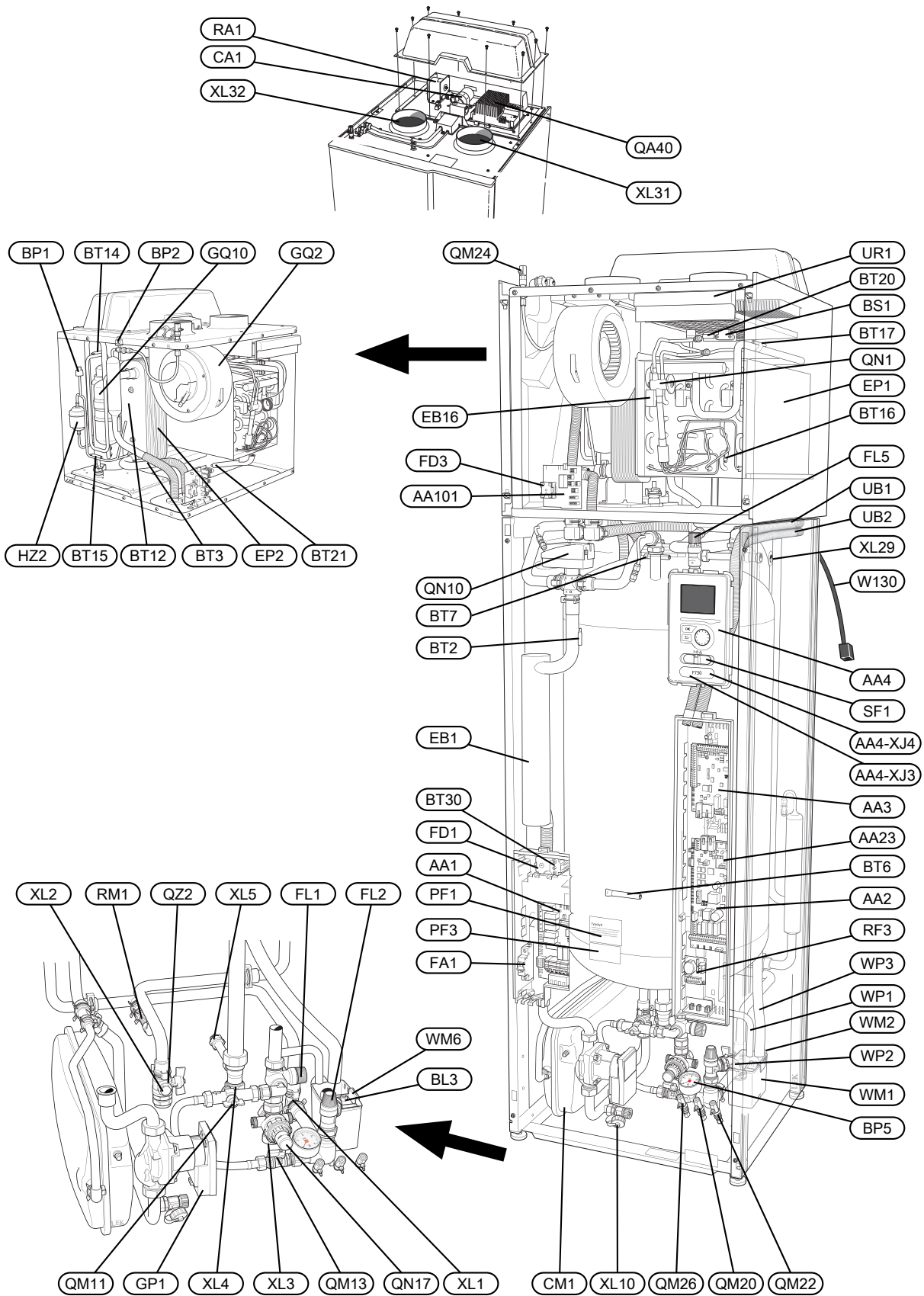

Pipe connections

XL1	Connection, heating medium flow line
XL2	Connection, heating medium return line
XL3	Connection, cold water
XL4	Connection, hot water
XL5	Connection, hot water circulation
XL10	Connection, draining heating medium
XL29	Connection, T&P valve (UK only)
XL31	Ventilation connection, exhaust air
XL32	Ventilation connection, extract air

HVAC components

CM1	Expansion vessel
FL1	Expansion relief valve, safety valve, hot water heater
FL2	Safety valve, climate system
FL5	T&P valve (UK only)
GP1	Circulation pump
QM11	Filler valve, climate system
QM13	Filler valve 2, climate system
QM20	Venting, heating medium
QM22	Venting, coil
QM24	Venting, heat exchanger
QM26	Venting, heating medium 2
QN10	Shuttle valve, climate system/water heater
QN17	Pressure reduction valve with integrated non-return valve (UK only)
QZ2	Filterball
RM1	Non-return valve
WM1	Overflow cup
WM2	Overflow water discharge
WM6	Overflow cup for level sensor
WP1	Overflow pipe, safety valve hot water heater
WP2	Overflow pipe, safety valve climate system
WP3	Overflow pipe, condensation

Sensors etc.

BL3	Level monitor for the overflow cup
BP1	High pressure pressostat
BP2	Low pressure pressostat
BP5	Pressure gauge, heating system
BS1	Air speed sensor
BT1	Outside sensor ¹
BT2	Temperature sensors, heating medium flow
BT3	Temperature sensors, heating medium return
BT6	Temperature sensor, hot water, control
BT7	Temperature sensor, hot water, display
BT12	Temperature sensor, heating medium flow after condenser
BT14	Temperature sensor, hot gas

BT15	Temperature sensor, fluid pipe
BT16	Temperature sensor, evaporator ¹
BT17	Temperature sensor, suction gas
BT20	Temperature sensor, exhaust air
BT21	Temperature sensor, extract air
BT30	Thermostat, backup heating
BT50	Room sensor ¹

Electrical components

AA1	Immersion heater card
AA2	Base card
AA3	Input circuit board
AA4	Display unit
	AA4-XJ3 USB socket
	AA4-XJ4 Service socket
AA23	Communication board
AA101	Connection card sensor
CA1	Capacitor
EB1	Immersion heater
EB16	Defrosting element
FA1	Miniature circuit-breaker
FD1	Temperature limiter
FD3	Temperature limiter, defrosting element
QA40	Inverter
RA1	Choke
RF3	EMC card
SF1	Switch
W130	Network cable for NIBE Uplink™

Cooling components

EP1	Evaporator
EP2	Condenser
GQ10	Compressor
HZ2	Drying filter
QN1	Expansion valve

Ventilation

GQ2	Exhaust air fan
HQ10	Exhaust air filter ¹
UR1	Filter cover, exhaust air

Miscellaneous

PF1	Rating plate
PF3	Serial number plate
UB1-2	Cable gland

¹Not visible in the image

Designations in component locations according to standard IEC 81346-2.

4 Pipe and ventilation connections

General pipe connections

Pipe installation must be carried out in accordance with current norms and directives.

The system requires the radiator circuit to be designed for a low temperature heating medium. At the lowest dimensioned outdoor temperature (DOT) the highest recommended temperatures are 55 °C on the supply line and 45 °C on the return line.

- NOTE**
The pipe system needs to be flushed out before the heat pump is connected so that any debris cannot damage component parts.
- NOTE**
This installation is subject to building regulation approval, notify the local Authority of intention to install.
- NOTE**
Use only manufacturer's recommended replacement parts.

Overflow water from the safety valves and the evaporator's collection tray passes via a non-pressurised overflow pipe to a drain, so that hot water splashes cannot cause injury. The mouth of the overflow pipe must be visible and not placed close to electrical components. In addition, the mouth of the overflow pipe (tundish), drain valves and motorised valves should be positioned away

from all electrical components. This is the only permitted use of non-pressurised overflow pipe. Overflow pipes from tundish connected to the expansion relief valve must also be connected to the drain in the same way.

Please note that the connection of the T&P-valve should not be used for any other purpose.

Valves may not be positioned between the safety valve and the water heater.

Overflow pipes from tundish must be routed with a fall and be at least 300 mm long, before bends or angles in the pipework (see image) and must also be frost-proof.

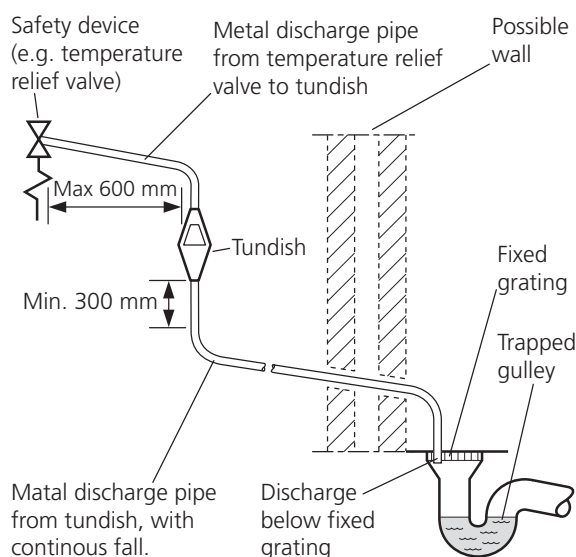

Valve outlet size	Minimum size of discharge pipe	Minimum size of discharge pipe from tundish	Maximum resistance allowed, expressed as a length of straight pipe (i.e. no elbows or bends)	Resistance created by each elbow or bend
G1/2	15 mm	22 mm	up to 9 m	0.8 mm
G1/2	15 mm	28 mm	up to 18 m	1.0 mm
G1/2	15 mm	35 mm	up to 27 m	1.4 mm
<G3>/4	22 mm	28 mm	up to 9 m	1.0 mm
<G3>/4	22 mm	35 mm	up to 18 m	1.4 mm
<G3>/4	22 mm	42 mm	up to 27 m	1.7 mm
G1	28 mm	35 mm	up to 9 m	1.4 mm
G1	28 mm	42 mm	up to 18 m	1.7 mm
G1	28 mm	54 mm	up to 27 m	2.3 mm

Hard water areas

Usually, there should not be a problem in installing F730 in areas of hard water as the operating temperature is 50-60 °C.

Cleaning the climate system

When the water heater and the climate system have been filled with water, F730 must operate at maximum normal temperature for at least one hour. Thereafter the system must be drained of water and refilled. See section Draining the climate system on page 51.

Before installing the heat pump in an existing system, it is important that the system is properly flushed through.

Even if the heat pump is to be installed in a new system, the heat pump and system should be flushed.



NOTE

Ensure that cleaning agent has been removed from the entire system before adding inhibitor.

After flushing an inhibitor should be used for long-term anti-corrosion protection.

NIBE Energy Systems Limited recommends water treatments (supplied by e.g. Fernox and Sentinel) specifically designed for heat pumps.



Caution

Ensure that incoming water is clean. When using a private well, it may be necessary to supplement with an extra water filter.

Max. volume in the heating section and the climate system

The volume of the pressure expansion vessel (CM1) is 10 litres and it is pre-pressurised as standard to 0.5 bar (5 mvp). As a result, the maximum permitted height "H" between the expansion vessel and the highest installed radiator is 5 m, see figure.

If the pre-pressure is not high enough, it can be increased by adding air via the valve in the expansion vessel. The expansion vessel's pre-pressure must be stated in the inspection document. Any change in the pre-pressure affects the ability of the expansion vessel to handle the expansion of the water.

The maximum system volume, excluding the heating section, is 285 litres at the above pre-pressure.

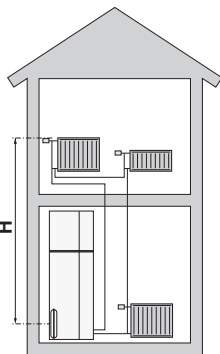

System diagram

When the exhaust air at room temperature passes through the evaporator, the refrigerant evaporates because of its low boiling point. In this way the energy in the room air is transferred to the refrigerant.

The refrigerant is then compressed in a compressor, causing the temperature to rise considerably.

The warm refrigerant is led to the condenser. Here the refrigerant gives off its energy to the heating system water, whereupon the refrigerant changes state from gas to liquid.

The refrigerant then goes via filters to the expansion valve, where the pressure and temperature are reduced.

The refrigerant has now completed its circulation and returns to the evaporator.

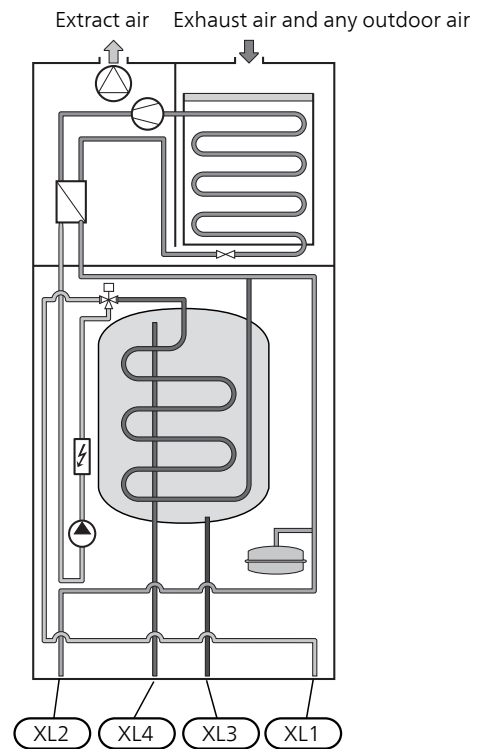

- XL1 Connection, heating medium flow
- XL2 Connection, heating medium return
- XL3 Connection, cold water
- XL4 Connection, hot water



Caution

This is an outline diagram, differences may occur in the actual installation.

Dimensions and pipe connections

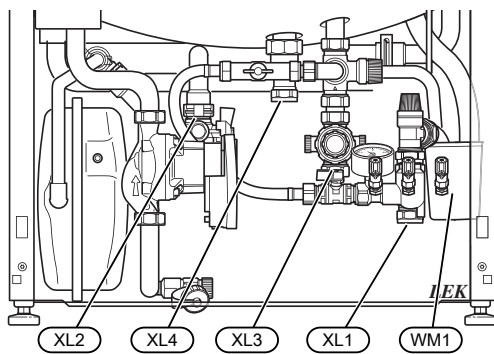
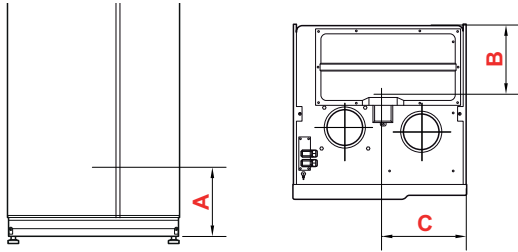

The overflow cup (WM1) can be turned, so that the pipe can be directed forwards or backwards to simplify connection of the hose to the drain.











Setting out dimensions

Connection		A	B	C
XL1 Heating medium supply	(mm)	150	285	105
XL2 Heating medium return	(mm)	220	285	365
XL3 Cold water	(mm)	210	445	195
XL4 Hot water	(mm)	300	405	260
WM1 Overflow cup	(mm)	200	280	50

Pipe dimensions

Connection		
XL1-XL2 Heating medium ext Ø	(mm)	22
XL3 Cold water ext Ø	(mm)	22
XL4 Hot water ext Ø	(mm)	22
XL5 Hot water circulation ext. Ø	(mm)	15
WM2 Overflow water discharge	(mm)	32

Symbol key

Symbol	Meaning
	Shut-off valve
	Non-return valve
	Mixing valve
	Shunt / shuttle valve
	Safety valve
	Temperature sensor
	Circulation pump
	Radiator system
	Domestic hot water
	Under floor heating systems

Cold and hot water

Connecting cold and hot water

- A mixer valve must also be installed, if the factory setting for hot water is changed. National regulations must be observed.
- The setting for hot water is made in menu 5.1.1 (page 45).

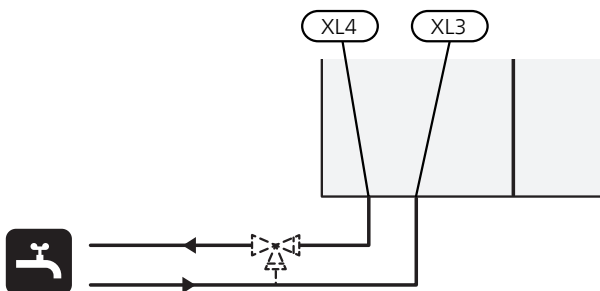

Heating medium side

Connecting the climate system

A climate system is a system that regulates indoor comfort with the help of the control system in F730 and for example radiators, under floor heating/cooling, fan coils etc.

- When connecting to a system with thermostats on all radiators, a relief valve must be fitted, or some of the thermostats must be removed to ensure sufficient flow.

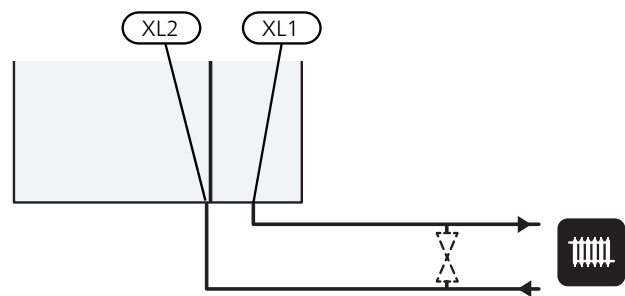

Installation alternative

F730 can be installed in several different ways, some of which are shown below.

Further option information is available at www.nibe.co.uk and in the respective assembly instruction for the accessory used. See page 56 for a list of accessories that can be used with F730.

Separated/one unit

F730 is delivered separated and can be installed separated or as one unit. For separate installation the accessory DK1 10 is required. Clips, o-rings and screws are supplied for both types of installation.

The images in this manual show F730 installed as one unit.



One unit



Separated installation

One unit

1. Remove the heater unit front hatch (see page 10).
2. Remove the insulation at the immersion heater (see page 11).
3. Remove the motor for the reversing valve for the climate system/water heater (QN10) (see page 10).
4. Remove the top insulation (see page 10).
5. Place the air treatment unit above the water heater unit by sliding the rear part of the air treatment unit into the water heater unit.
6. Then lower the front part of the air treatment unit. The locking tabs are then located in grooves in the heater unit.

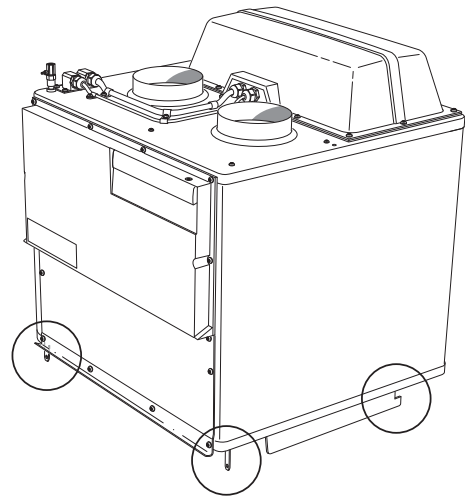

7. Secure condensation hoses in the air treatment unit.

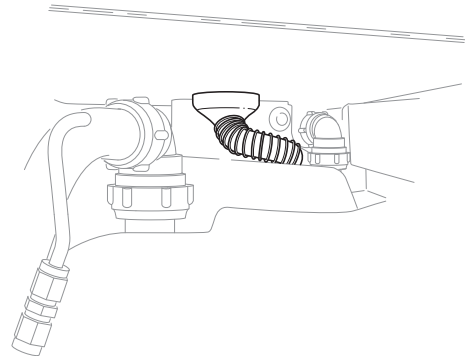

TIP

Lift the air treatment unit slightly at the front edge so that it is easier to access.

8. Install an overflow cup and route the condensation hose to it.

9. Connect the air treatment unit flexible pipes to the heater unit. Use the o-rings and clips supplied.

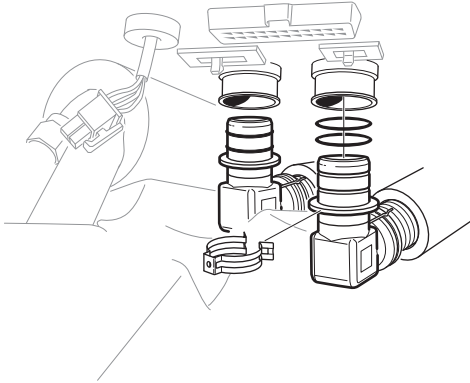

10. Connect the air treatment unit wiring to the heater unit.

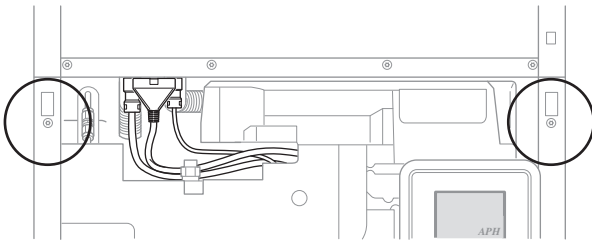

11. Secure the air treatment unit lock tabs in the water heater unit with 2 of the screws supplied.
12. Install the reversing valve motor and the heater unit insulation.
13. Secure the side panels on the air treatment unit with 2 of the remaining screws supplied. The side panels mounting points may need to be adjusted slightly.

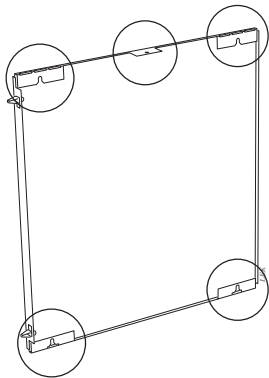

Side hatches mounting points

14. Install the front panels on the air treatment and heater units.

Outdoor air operation

Explanation

EB100 F730

BT28 Ambient sensor

QN38 Outdoor air damper

RN1 Adjustment damper¹

¹Not supplied F730

Designations according to standard IEC 61346-2.

Outline diagram

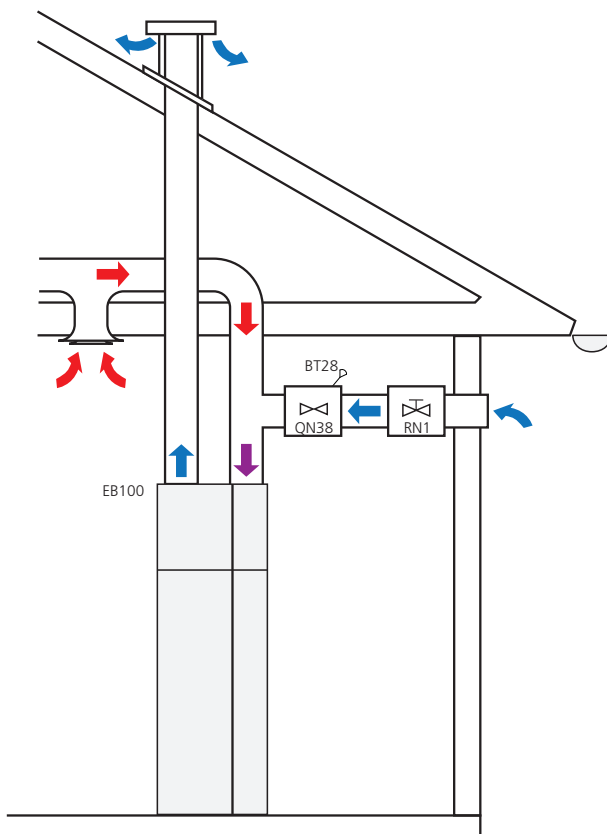

The hot air is transferred from the rooms to the heat pump (EB100) via the building's ventilation system.

The outdoor air is moved via an outdoor air duct via the outdoor air damper (QN38), adjustment damper (RN1) to the heat pump (EB100).

Where no adjustment damper (RN1) is used, the opening angle set for the damper motor can be used to adjust the air flows. The damper motor's opening angle is adjusted using the stop screw, see image.

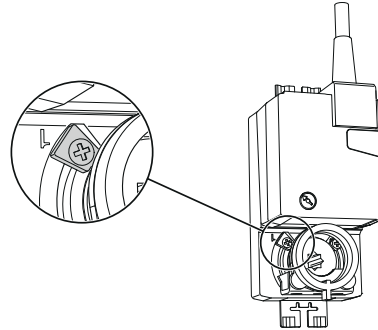

NOTE

The outdoor air temperature has a very low temperature. To avoid damaging F730 and/or the house, it is therefore important that the damper section, motor shelf and outdoor air duct are insulated with diffusion-proof material. The outdoor air duct must be insulated over its entire length.



TIP

Install the dampers etc. in such a way that they are easily accessible for any service.

Mounting

Before installation, check that the motor's direction of rotation is set according to the image:

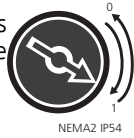

1. Disconnect the power from the heat pump.
2. Connect the damper motor electrically, see page 27.
3. Connect the supply to F730. Check that miniature circuit-breaker (FA1) has not tripped. Set the heat pump's switch (SF1) to position "I".
4. The damper motor now runs to the limit position for closed damper.
5. Install the damper motor on the outdoor air damper (QN38).



Caution

Ensure that the damper is closed before installing the motor.

6. Insert the temperature sensor (BT28) through the cable grommet on the outdoor air damper.
7. Install the outdoor air damper in the duct.



Caution

Install the damper so that the temperature sensor (BT28) is turned towards incoming air. The damper must be in the closed position when it is installed in the duct.

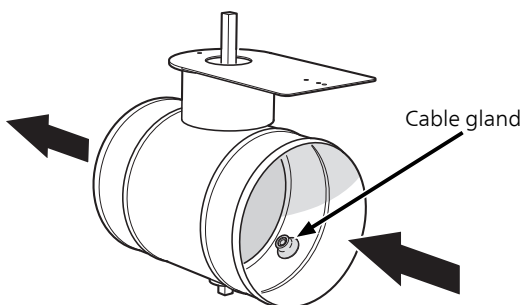

Adjusting ventilation

Activate ventilation adjustment for the outdoor air mixture in menu 5.3.17 "outdoor air mixing". During the time that the adjustment is active, the fan runs according to the set value "fan speed outdoor air" and the outdoor air damper is open.

1. Enter menu 5.3.17 "outdoor air mixing".
2. Tick "adjusting ventilation". The outdoor air damper opens and the fan changes speed. The compressor is stopped, if it is running, and the circulation pump starts, if it is off.
3. Measure the airflow at the ventilation device.
4. If the ventilation flow is too high at outdoor air mixing, reduce the fan speed.
5. If the ventilation flow is too low at maximum fan speed, restrict the outdoor air damper or reduce the outdoor air damper's (QN38) degree of opening using the stop screws on the damper motor.



NOTE

During high fan speed combined with a short outdoor air duct, the total air flow can be higher than the air flow sensor's (BS1) measurement range. The heat pump then shows the info text "Fan setting too high, reduce set fan speed" and/or alarm "Err: BS1 air speed sensor".

Extra hot water heaters

The heat pump should be supplemented with an extra water heater, if a large bath tub or other significant consumer of hot water is installed.

Water heater without immersion heater

In water heaters without an immersion heater the water is heated by the heat pump's compressor.

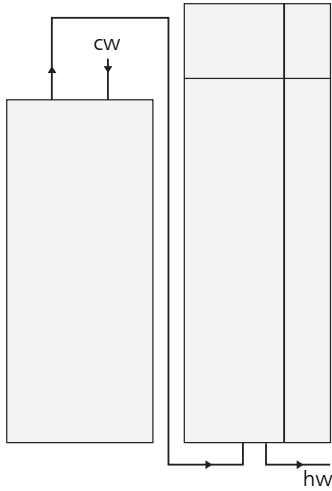

Water heater with immersion heater

If it is possible to use a water heater with an immersion heater, connect it as illustrated below.

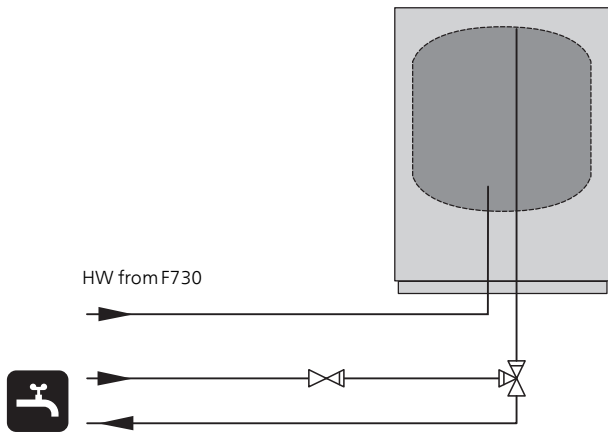

Hot water circulation (VVC)

To reduce the risk of bacterial growth in systems with hot water circulation, the temperature of the circulating water should not fall below 50°C. Nor should there be any hot water pipes containing stationary water. Adjust the hot water system so that the temperature does not fall below 50°C at the extremities of the system.

The circulation pump for hot water circulation can be controlled by the heat pump. The HWC return can be connected to XL5 or a freestanding water heater. If an electric water heater is connected after the heat pump, the HWC return must be connected to the water heater.

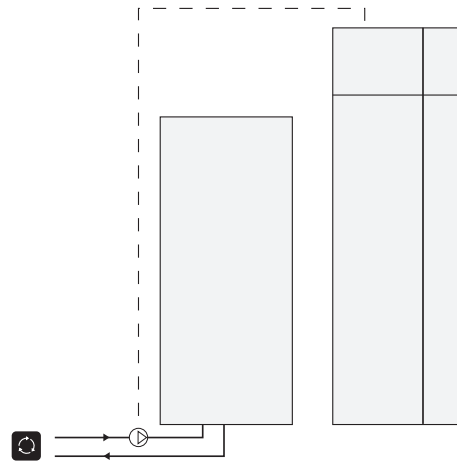

Two or more climate systems

When more than one climate system is to be heated, the following connection can be used.

The ECS 40/ECS 41 accessory is required for this connection.

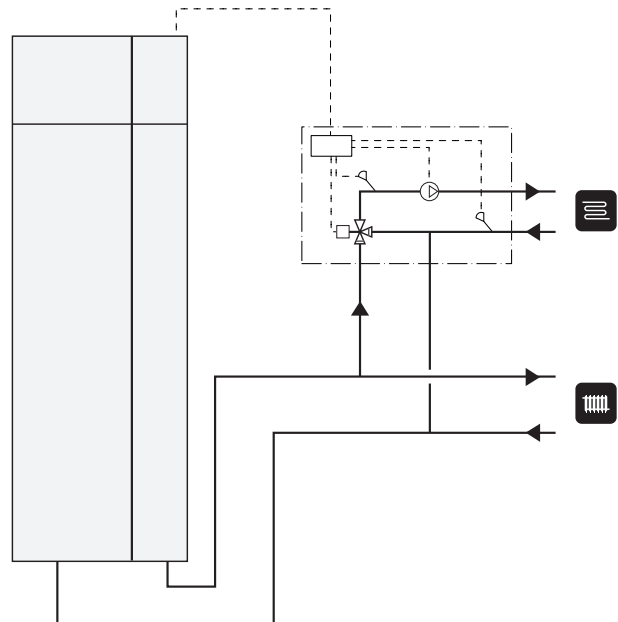

General ventilation connection

- Ventilation installation must be carried out in accordance with current norms and directives.
- Connections must be made via flexible hoses, which should be installed so that they are easy to replace.
- Provision must be made for inspection and cleaning of the duct.
- Make sure that there are no reductions of cross-sectional area in the form of creases, tight bends, etc., since this will reduce the ventilation capacity.
- The air duct system must be a minimum of air tightness class B.
- To prevent fan noise being transferred to the ventilation devices, silencers should be installed in the duct system. In the event of ventilation devices in noise-sensitive rooms, silencers must be installed.
- The extract air and outdoor air ducts are insulated using diffusion-proof material along their entire lengths.
- Ensure that the condensation insulation is thoroughly sealed at any joints and/or at lead-in nipples, silencers, roof cowls, outdoor air dampers or similar.
- The ventilation ducts should be installed in such a way that it is easy to open the inverter box.
- A duct in a masonry chimney stack must not be used for extract air.



NOTE

F730 occasionally has a very low extract air and outdoor air temperature. To avoid damaging the product and/or the building, it is therefore important that the extract and outdoor air ducts, the damper section and the motor shelf are insulated with diffusion-proof material along their entire length.



TIP

If additional condensation insulation dimension $\varnothing 200$ is installed on the outside of the existing exhaust line between the heat pump and the inner roof, the noise in the installation area is reduced by 1-2 dB(A).

Exhaust air duct /kitchen fan

Exhaust air duct (kitchen fan) must not be connected to F730.

To prevent cooking odours from being led to the F730, the distance between the kitchen fan and the exhaust air valve must be observed. The distance should not be less than 1.5 m.

Always use a kitchen fan when cooking.

Ventilation flow

Connect F730 so that all the exhaust air, except kitchen duct air (kitchen fan), passes through the evaporator (EP1) in the heat pump.

The ventilation flow must comply with the applicable national standards.

For optimum heat pump performance, the ventilation flow should not be less than 21 l/s (75 m³/h).

Set the ventilation capacity in the heat pump's menu system (menu 5.1.5).

If the exhaust air temperature falls below 6°C, the compressor is blocked and electric additional heat is permitted. No energy is recovered from the exhaust air when the compressor is blocked.

Adjusting ventilation

To obtain the necessary air exchange in every room of the house, the exhaust air devices must be correctly positioned and adjusted and the fan in the heat pump adjusted.

Immediately after installation adjust the ventilation so that it is set according to the projected value of the house.

Incorrect adjustment of the ventilation may lead to reduced installation efficiency and thus poorer operating economy, and may cause moisture damage in the building

Dimension and ventilation connections

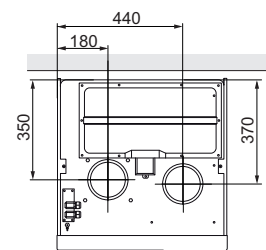
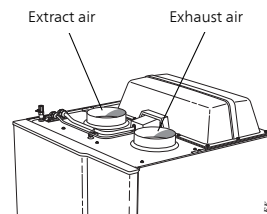

5 Electrical connections

General

All electrical equipment, except the outdoor sensors, room sensors and the outdoor damper, is already connected at the factory.

- Disconnect the heat pump before any insulation test of the house wiring is carried out.
- F730 should be equipped with a separate RCD (30 mA).
- If a miniature circuit breaker is used, this should have at least motor characteristic "C". See page 59 for fuse size.
- For the heat pump wiring diagram, see page 63.
- Communication and sensor cables to external connections must not be laid close to high current cables.
- The minimum area of communication and sensor cables to external connections must be 0.5 mm² up to 50 m, for example EKKX or LiYY or equivalent.
- When cable routing in F730, cable grommets UB1 and UB2, (marked in image) must be used. In UB1 and UB2 the cables are inserted through the heat pump from the back to the front. For dimensions diagram see page 26.

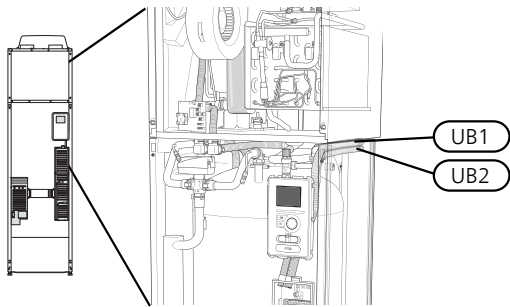

NOTE

Switch (SF1) must not be moved to "I" or "△" until F730 has been filled with water. Otherwise the temperature limiter, thermostat and the immersion heater may be damaged.



NOTE

Check the connections, main voltage and phase voltage before the machine is started, to prevent damage to the heat pump electronics.



NOTE

If the supply cable is damaged, only NIBE, its service representative or similar authorised person may replace it to prevent any danger and damage.



NOTE

Electrical installation and service must be carried out under the supervision of a qualified electrician. Cut the current with the circuit breaker before carrying out any servicing. Electrical installation and wiring must be carried out in accordance with the stipulations in force.

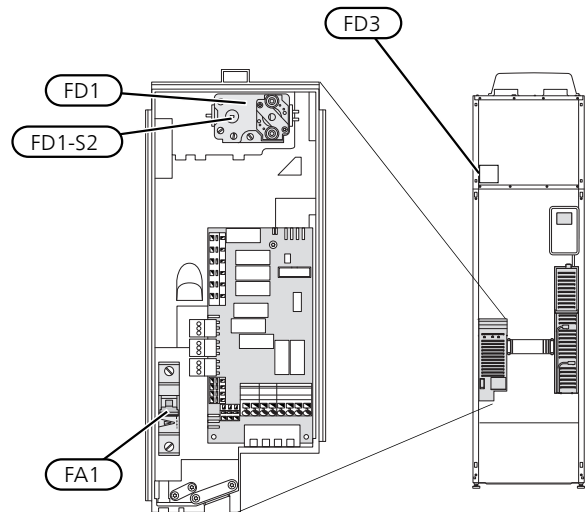

Miniature circuit breaker (FA1)

Operation (230V), fan, circulation pumps etc. are internally fused by a miniature circuit breaker (FA1).



Caution

Check the miniature circuit-breaker (FA1). It may have tripped during transportation.

Temperature limiter (FD1)

The temperature limiter (FD1) cuts the current supply to the electric additional heat if the temperature rises between 90 and 100°C and can be manually reset.

Resetting

The temperature limiter (FD1) is accessible behind the front cover. Reset the temperature limiter by carefully pressing the button (FD1-SF2) using a small screwdriver.

Temperature limiter, defrosting element (FD3)

The temperature limiter for the defrosting element (FD3) cuts the current supply to the defrosting element if the temperature rises above 75 °C and is manually reset.

Resetting

The temperature limiter for the defrosting element (FD3) is accessible behind the air treatment cover. Remove the cover and then the panel secured with screws. Reset the temperature limiter by carefully pressing the button (FD3-SF2) using a small screwdriver.

Accessibility, electrical connection

The plastic cap of the electrical boxes is opened using a screwdriver.



NOTE

The cover for the input card is opened without a tool.

Removing the cover, input board

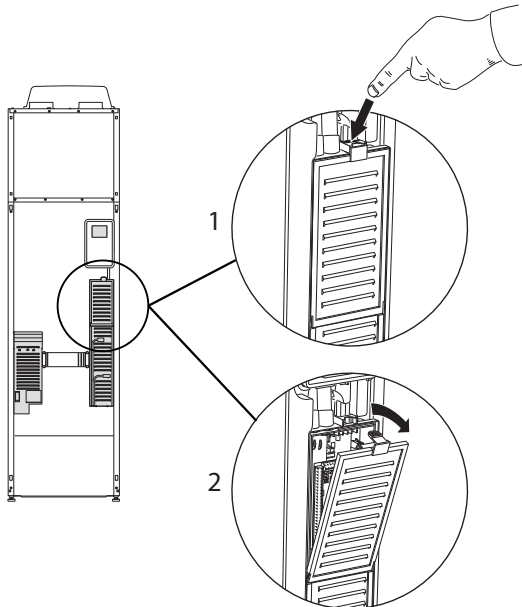

1. Push the catch down.
2. Angle out the cover and remove it.

Removing the cover, immersion heater board

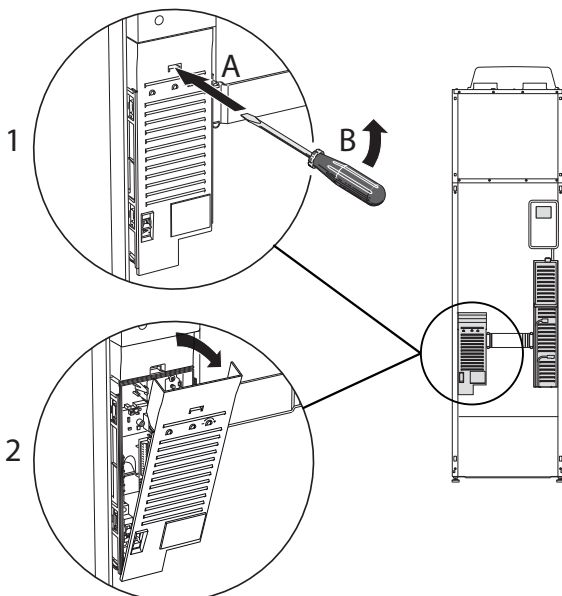

1. Insert the screwdriver (A) and pry the catch carefully downwards (B).
2. Angle out the cover and remove it.

Removing the cover, base circuit board



Caution

To remove the cover for the base board, the cover for the input circuit board must first be removed.

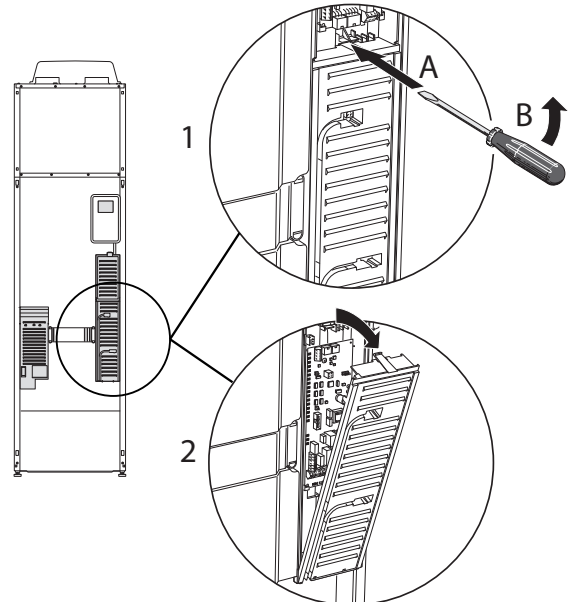

1. Insert the screwdriver (A) and pry the catch carefully downwards (B).
2. Angle out the cover and remove it.

Cable lock

Use a suitable tool to release/lock cables in the heat pump terminal blocks.

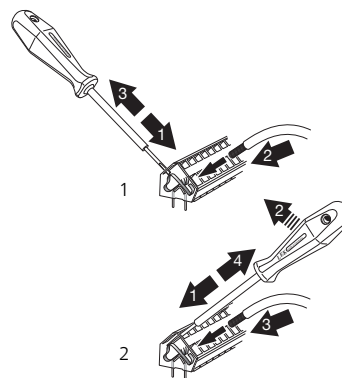

Connections



NOTE

To prevent interference, unshielded communication and/or sensor cables to external connections must not be laid closer than 20 cm from high voltage cables.

Power connection

F730 must be installed via an isolator switch with a minimum breaking gap of 3mm. Minimum cable area must be sized according to the fuse rating used. Supplied cable (length approx. 2 m) for incoming supply electricity is connected to terminal block X1 on the immersion heater board (AA1). The connection cable can be found on the back of F730 (see dimensions diagram below).

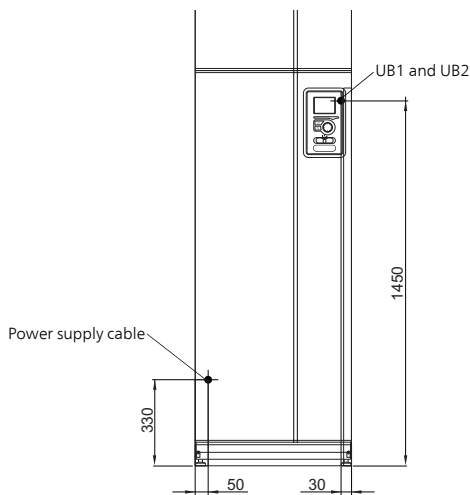

Connection 1x230V

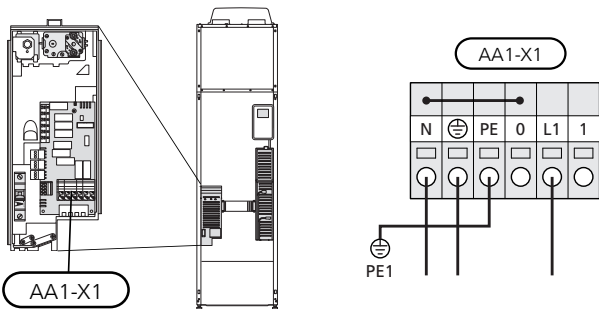

Tariff control

If the voltage to the immersion heater and/or the compressor disappears for a certain period, there must also be blocking via the AUX-input at the same time, see "Possible selection for AUX inputs".

Outside sensor

Install the outdoor temperature sensor (BT1) in the shade on a wall facing north or north-west, so it is unaffected by the morning sun for example.

Connect the sensor to terminal block X6:1 and X6:2 on the input board (AA3). Use a twin core cable of at least 0.5 mm² cable area.

If a conduit is used it must be sealed to prevent condensation in the sensor capsule.

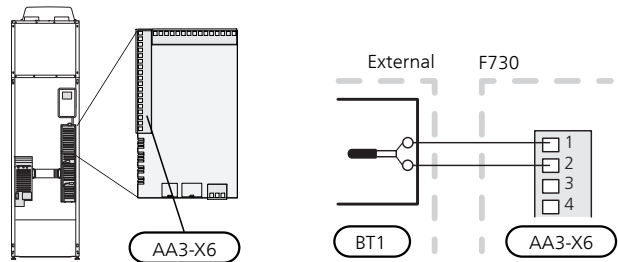

Ambient sensor

The ambient sensor (BT28) is placed in the cable gland in the outside air damper with a protrusion of 10-20 mm.

Connect the sensor to terminal block X6:7 and X6:8 on the input board (AA3). Use a twin core cable of at least 0.5 mm² cable area.

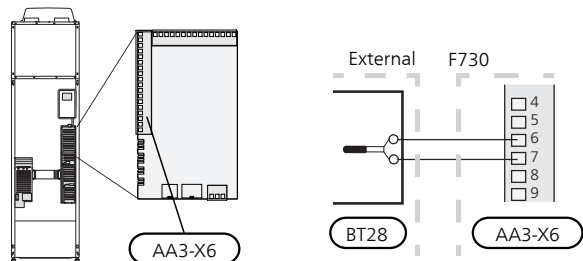

Room sensor

F730 is supplied with a room sensor enclosed (BT50). The room sensor has a number of functions:

1. Shows current room temperature in the display on F730.
2. Option of changing the room temperature in °C.
3. Provides the option of fine-tuning the room temperature.

Install the sensor in a neutral position where the set temperature is required. A suitable location is on a free inner wall in a hall approx. 1.5 m above the floor. It is important that the sensor is not obstructed from measuring the correct room temperature by being located, for example, in a recess, between shelves, behind a curtain, above or close to a heat source, in a draft from an external door or in direct sunlight. Closed radiator thermostats can also cause problems.

The heat pump operates without the sensor, but if one wishes to read off the accommodation's indoor temperature in F730's display, the sensor must be installed. Connect the room sensor to X6:3 and X6:4 on the input board (AA3).

If the sensor is to be used to change the room temperature in °C and/or to fine-tune the room temperature, the sensor must be activated in menu 1.9.4.

If the room sensor is used in a room with underfloor heating, it should only have an indicatory function, not control of the room temperature.

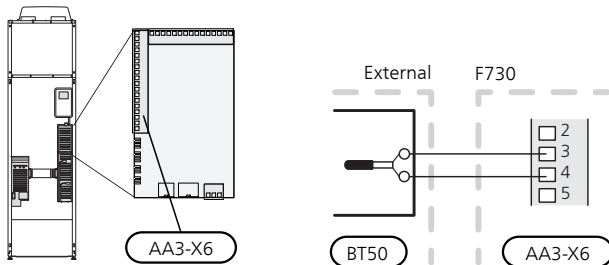

Caution

Changes of temperature in accommodation take time. For example, short time periods in combination with underfloor heating will not give a noticeable difference in room temperature.

Outdoor air damper

Connect the damper motor (QN38) to AA2-X4.

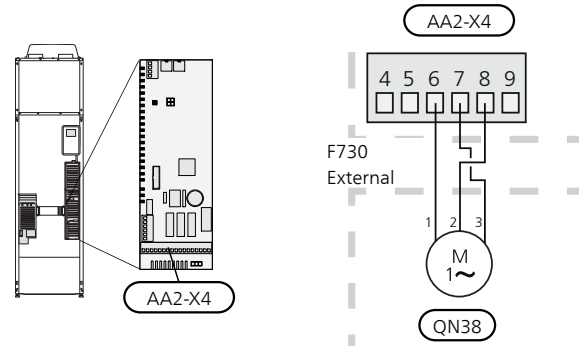

The switch for the direction of rotation of the motor is set at the factory as below.

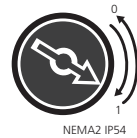

Settings

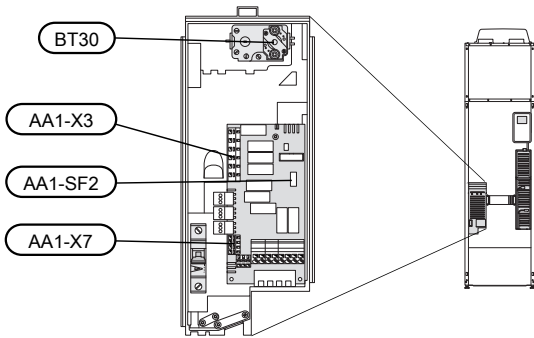

Electrical addition - maximum output

The immersion heater can be set to a maximum of 3.5 kW which is the delivery setting.

The immersion heater output is divided into steps, according to the table.

Setting maximum output in the electric additional heat is done in menu 5.1.12.

Power steps of the immersion heater

Electrical addition (kW)	Max (A)
0.0	1.2
0.5	3.4
1.0	5.5
1.5	7.7
2.0	9.9
2.5	12.1
3.0	14.2
3.5*	16.4

*Default value

The table displays the maximum phase current at each electrical step for the heat pump (without compressor operation).

In addition to this, there is the current for compressor operation, which, depending on the operating conditions, can amount to approx. 13A.

The heat pump is fused to at least 16 A.

Emergency mode

When the heat pump is set to emergency mode (SF1 is set to Δ), only the most necessary functions are activated.

- The compressor is off and heating is managed by the immersion heater.
- Hot water is not produced.

Power in emergency mode

The immersion heater's output in emergency mode is set with the dipswitch (S2) on the immersion heater circuit board (AA1) according to the table below.

kW	1	2	3	4	5	6
0.5	on	off	off	off	off	off
1.0	off	off	on	off	off	off
1.5	on	off	on	off	off	off
2.0	off	off	off	off	on	off
2.5	on	off	off	off	on	off
3.0	off	off	on	off	on	off
3.5*	on	off	on	off	on	off

*Default value

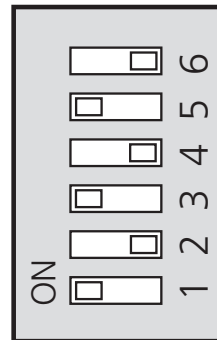

The image shows the dip-switch (AA1-S2) in the factory setting.

Emergency mode thermostat

The supply temperature in emergency mode is set using a thermostat (FD1-BT30). It can be set to 35 (pre-set, for example under floor heating) or 45 °C (for example radiators).

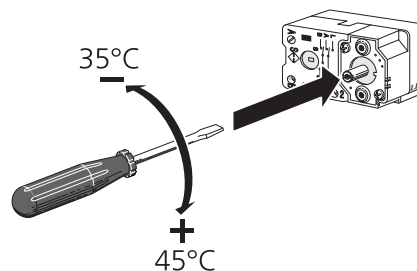

Optional connections

Load monitor

Integrated load monitor

F730 is equipped with a simple form of integrated load monitor, which limits the power steps for the electric additional heat by calculating whether future power steps can be connected to the relevant phase without the specified main fuse being exceeded. In those cases where the current would exceed the specified main fuse, the power step is not permitted. The size of the property's main fuse is specified in menu 5.1.12.

NIBE Uplink

Connect the network connected cable (straight, Cat.5e UTP) with RJ45-contact (male) to RJ45 contact (female) on the rear of the heat pump.

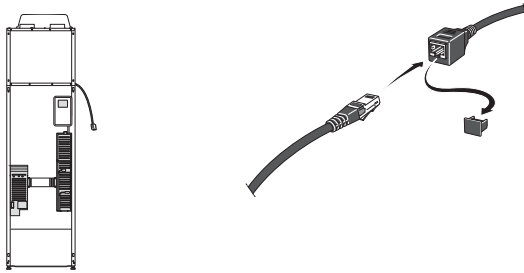

External connection options

F730 has software-controlled AUX inputs and outputs on the input board (AA3), for connecting the external switch function or sensor. This means that when an external switch function (the switch must be potential-free) or sensor is connected to one of six special connections, this function must be selected for the correct connection in menu 5.4.

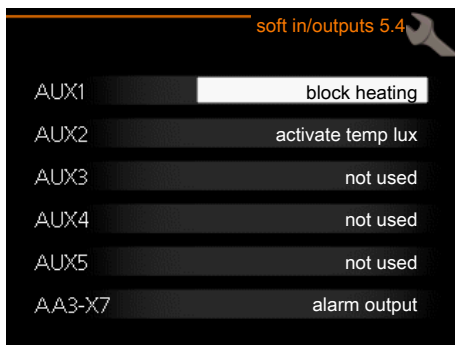

For certain functions, accessories may be required.

Selectable inputs

Selectable inputs on the input board for these functions are:

AUX1	AA3-X6:9-10
AUX2	AA3-X6:11-12
AUX3	AA3-X6:13-14
AUX4	AA3-X6:15-16

AUX5

AA3-X6:17-18

Selectable outputs

A selectable output is AA3-X7.

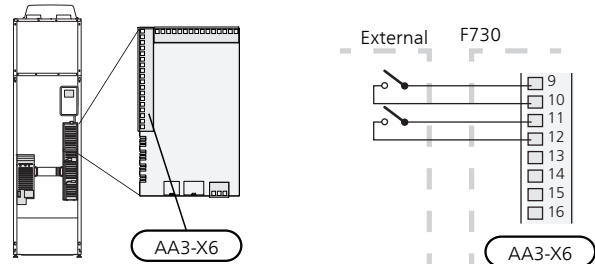

The example above uses the inputs AUX1 (X6:9-10) and AUX2 (X6:11-12) on the input board (AA3).



Caution

Some of the following functions can also be activated and scheduled via menu settings.

Possible selection for AUX inputs

Temperature sensor

Temperature sensor can be connected to F730. Use a 2-core cable of at least 0.5 mm² cable area.

Available options are:

- room sensor (RTS 40)

Monitor

Available options are:

- alarm from external units. The alarm is connected to the control, which means that the malfunction is presented as an info-alarm in the display. Potential-free signal of type NO or NC.

External blocking of functions

An external switch function can be connected to F730 for blocking various functions. The switch must be potential-free and a closed switch results in blocking.



Caution

Blocking entails a risk of freezing.

Functions that can be blocked:

- hot water (hot water production)
- heating (blocking of heating demand)
- additional heat (additional heat is blocked)
- compressor
- tariff blocking (additional heat, compressor, heating and hot water are disconnected)

External activation of functions

An external switch function can be connected to F730 to activate various functions. The function is activated during the time the switch is closed.

Possible functions that can be activated:

- hot water function "temporary lux"
- hot water comfort mode "economy"
- "external adjustment"

An external contact function can be connected to F730 to change the supply temperature and the room temperature.

When the switch is closed, the temperature changes in °C (if the room sensor is connected and activated). If a room sensor is not connected or not activated, the desired change of "temperature" (heating curve offset) is set with the number of steps selected. The value is adjustable between -10 and +10. External adjustment of climate systems 2 to 8 requires accessories.

– *climate system 1 to 8*

The value for the change is set in menu 1.9.2, "external adjustment".

- activation of one of four fan speeds.

The following five options are available:

- 1-4 is normally open (NO)
- 1 normally closed (NC)

The fan speed is activated during the time the switch is closed. Normal speed is resumed when the switch is opened again.

- SG ready



Caution

This function can only be used in mains networks that support the "SG Ready"-standard

"SG Ready" requires two AUX inputs.

"SG Ready" is a smart form of tariff control where your electricity supplier can affect the indoor and hot water temperatures or simply block the additional heat and/or the compressor in the heat pump at certain times of the day (can be selected in menu 4.1.5 after the function is activated). Activate the function by connecting potential-free switch functions to two inputs selected in menu 5.4 (SG Ready A and SG Ready B).

Closed or open switch means one of the following:

– **Blocking (A: Closed, B: Open)**

"SG Ready" is active. The compressor in the heat pump and additional heat is blocked like the day's tariff blocking.

– **Normal mode (A: Open, B: Open)**

"SG Ready" is not active. No effect on the system.

– **Low price mode (A: Open, B: Closed)**

"SG Ready" is active. The system focuses on costs savings and can for example exploit a low tariff from the electricity supplier or over-capacity from any own power source (effect on the system can be adjusted in the menu 4.1.5).

– **Overcapacity mode (A: Closed, B: Closed)**

"SG Ready" is active. The system is permitted to run at full capacity at over capacity (very low price) with the electricity supplier (effect on the system is settable in menu 4.1.5).

(A = SG Ready A and B = SG Ready B)

- +Adjust

Using +Adjust, the installation communicates with the underfloor heating's control centre* and adjusts the heating curve and calculated supply temperature according to the underfloor heating system's reconnection.

Activate the climate system you want +Adjust to affect by highlighting the function and pressing the OK button.

*Support for +Adjust required



Caution

This accessory may require a software update in your F730. The version can be checked in the "Service info" menu 3.1. Visit <http://www.nibeuplink.com> and click on the "Software" tab to download the latest software to your installation.



Caution

In systems with both under floor heating and radiators, NIBE ECS 40/41 should be used for optimum operation.

Possible selections for AUX output

It is possible to have an external connection through the relay function via a potential-free switching relay (max. 2 A) on the input board (AA3), terminal block X7. The function must be activated in menu 5.4.

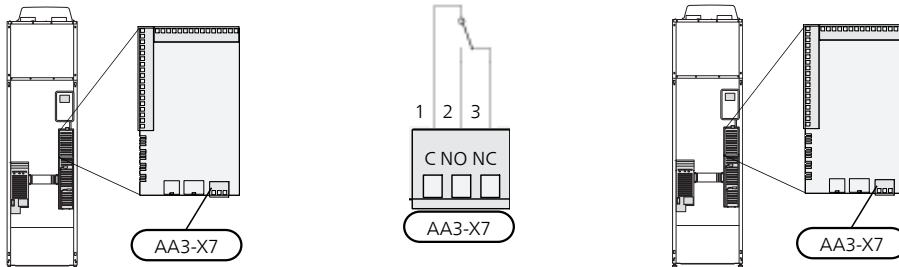

The picture shows the relay in the alarm position.

When the switch (SF1) is in the “⏻” or “⚠” position, the relay goes to NC.

Caution

The relay outputs may be subjected to a max load of 2 A at resistive load (230V AC).



TIP

The accessory AXC is required if more than one function is to be connected to the AUX output.

Optional functions for external connection:

Indication

- alarm indication
- holiday indication

Control

- control of circulation pump for hot water circulation
- control of external circulation pump (for heating medium)

Activation

- activation of away mode for smart home (complement to the functions in menu 4.1.7)

Caution

The relevant distribution box must be marked with a warning about external voltage.

An external circulation pump is connected to the AUX output, as illustrated below.

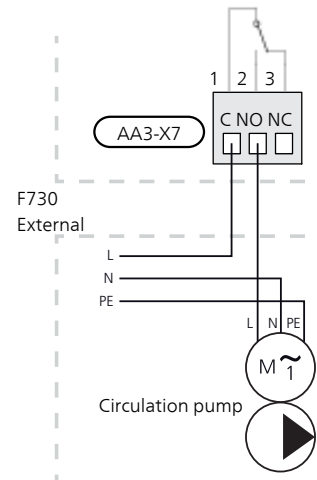

Connecting accessories

Instructions for connecting accessories are provided in the manual accompanying the accessory. See page 56 for the list of the accessories that can be used with F730.

6 Commissioning and adjusting

Preparations

1. Check that the switch (SF1) is in position "⏻".
2. Check that the filling valve (QM11) is fully closed.



Caution

Check the miniature circuit-breaker (FA1) in the heat pump. It may have tripped during transportation.

Filling and venting

Filling the hot water heater

1. Open a hot water tap in the house.
2. Open the externally mounted filler valve. This valve should then be fully open during operations.
3. When water comes out of the hot water tap, the hot water heater is full and the tap can be closed.

Filling the climate system

1. Open the vent valves (QM20), (QM22), (QM24) and (QM26).
2. Check that the supplied flexi hose is connected between connection (QM11) and connection (QM13). Connect the hose if this has not been done.
3. Open the filler valves (QM11), (QM13). The heating section and the rest of the climate system are filled with water.
4. When the water exiting the vent valves (QM20), (QM22), (QM24) and (QM26) is no longer mixed with air, close the valves. After a while, the pressure rises on the pressure gauge (BP5). When the pressure reaches 2.5 bar (0.25 MPa), the safety valve (FL2) starts to release water. Close the filler valves (QM11) and (QM13).
5. Reduce the pressure in the climate system to the normal working range (approx. 1 bar) by opening the vent valves (QM20), (QM22), (QM24) and (QM26) or the externally mounted safety valve.
6. Check that there is water in the overflow cup (WM1).
7. Start the heat pump and allow it to run in both heating and hot water modes.
8. Vent the climate system (see section "Venting the climate system").

If the overflow cup requires topping up:

1. Turn the safety valve for hot water (FL1) anticlockwise carefully.

Venting the climate system

1. Turn off the power supply to the heat pump.
2. Vent the heat pump via the vent valves (QM20), (QM22), (QM24), (QM26) and the rest of the climate system via the relevant vent valves.
3. Keep topping up and venting until all air has been removed and the pressure is correct.



NOTE

The vent hoses from the container must be drained of water before air can be released. This means that the system is not necessarily vented despite the flow of water when the vent valves (QM20), (QM22), (QM24), (QM26) are opened.

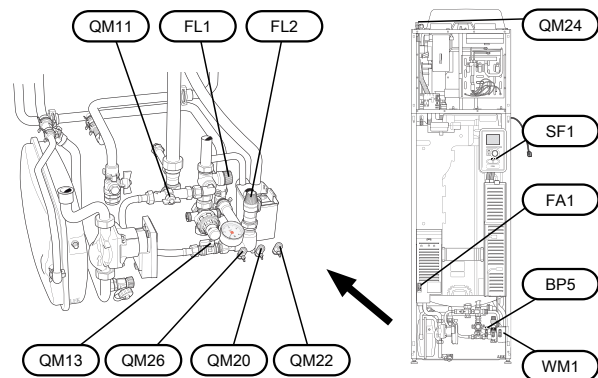

Start-up and inspection



NOTE

Warning: Do not start the heat pump if there is a risk that the water in the system has frozen.

Start guide



NOTE

There must be water in the climate system before the switch is set to "I".

1. Set switch (SF1) on F730 to position "I".
2. Follow the instructions in the display's start guide. If the start guide does not start when you start the F730, start it manually in menu 5.7.



TIP

See page 38 for a more in-depth introduction to the heat pump's control system (operation, menus etc.).

If the building is cooled when F730 starts, the compressor may not be able to meet the entire demand without having to use additional heating.

Commissioning

The first time the heat pump is started a start guide is started. The start guide instructions state what needs to be carried out at the first start together with a run through of the heat pump's basic settings.

The start guide ensures that start-up is carried out correctly and cannot be bypassed. The start guide can be started later in menu 5.7.



Caution

As long as the start guide is active, no function in the installation will start automatically.

The guide will appear at each installation restart until it is deselected on the last page.

Operation in the start guide

A. Page

B. Name and menu number

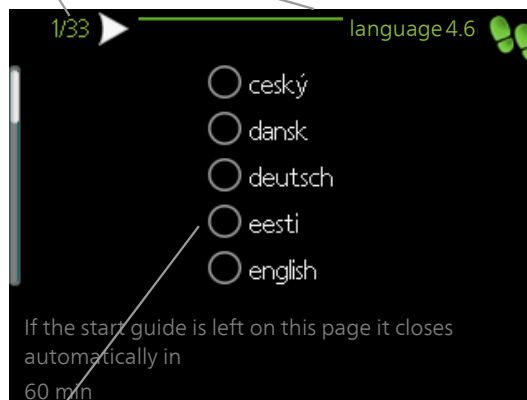

C. Option / setting

A. Page

Here you can see how far you have come in the start guide.

Scroll between the pages of the start guide as follows:

1. Turn the control knob until one of the arrows in the top left corner (at the page number) has been marked.
2. Press the OK button to skip between the pages in the start guide.

B. Name and menu number

Read what menu in the control system this page of the start guide is based on. The digits in brackets refer to the menu number in the control system.

If you want to read more about affected menus either consult the help menu or read the user manual.

C. Option / setting

Make settings for the system here.

D. Help menu

 In many menus there is a symbol that indicates that extra help is available.

To access the help text:

1. Use the control knob to select the help symbol.
2. Press the OK button.

The help text often consists of several windows that you can scroll between using the control knob.

Setting the ventilation

Ventilation must be set according to applicable standards. Set the fan speed in menu 5.1.5.

Even if ventilation is roughly set at installation it is important that a ventilation adjustment is ordered and permitted.



NOTE

Order a ventilation adjustment to complete the setting.

Ventilation capacity

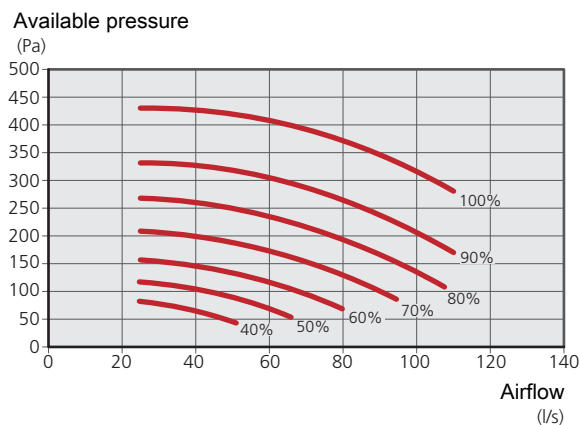

Fan rating

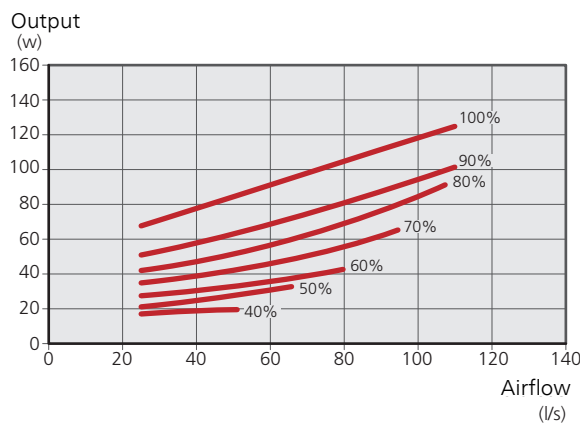

Adjusting the exhaust air flow

1. Enter menu 5.1.5 "fan sp. exhaust air".
2. Select "adjusting ventilation".
3. You now come to menu 5.1.5.1 "adjusting ventilation".
4. Tick "adjusting ventilation".
5. Measure the airflow at the ventilation device.
6. Adjust the fan speed to achieve desired ventilation.
7. Enter the metered air flow.
8. Back to menu 5.1.5.
9. The value for fan speed that you entered in the menu 5.1.5.1 is now copied to "normal".

Adjusting outdoor air mixture

1. Enter menu 5.3.17 "outdoor air mixing".
2. Tick "adjusting ventilation". The outdoor air damper opens and the fan changes speed. The compressor is stopped, if it is running, and the circulation pump starts, if it is off.
3. Measure the airflow at the ventilation device.
4. If the airflow is higher than the maximum for the machine, the information "Fan setting too high, reduce set fan speed" is given. Change the fan speed in menu 5.3.17.
5. If the airflow is higher than the maximum for the machine, the information "Fan setting too high, reduce set fan speed" is given. Change the fan speed in menu 5.3.17.

If the measured air flow is too low when the fan runs at 100%, restrict the outdoor air flow.

Commissioning without fan

The heat pump can be run without recovery, as only an electric boiler, to produce heat and hot water, for example before the ventilation installation is complete.

Enter menu 4.2 - "op. mode" and select "add. heat only"

Enter menu 5.1.5 - "fan sp. exhaust air" and reduce the fan speed to 0%.



NOTE

Select operating mode "auto" or "manual" when the heat pump is to run on recovery again.

Setting pump speed

The heat pump (GP1) is automatically controlled and sets itself using the controls and based on the heating demand.

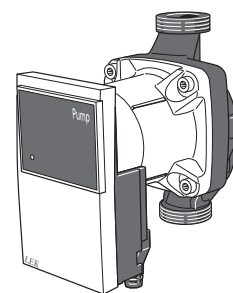

Capacity, heating medium pump

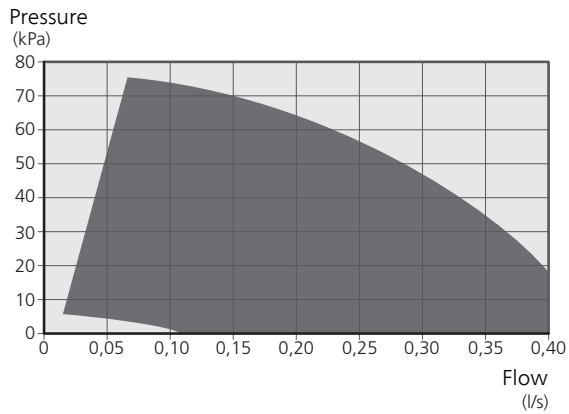

Output, heating medium pump

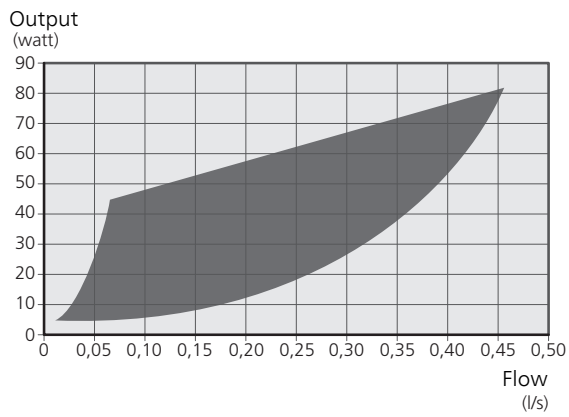

Post-adjustment, venting

Post-adjustment, venting

Air is initially released from the hot water and venting may be necessary. If gurgling sounds can be heard from the heat pump or climate system, the entire system requires additional venting. See section "Venting the climate system" on page 33 for information about venting the heat pump.

Basic values for the curve setting

The values stated on the map apply for the "heating curve" in menu 1.9.1

- The first value applies for low temperature* radiator systems. "temperature" (offset heating curve) in menu 1.1 must be set to -2.
- The value in brackets refers to under floor heating systems** installed in concrete floor structures.
- When the system is installed in a timber floor structure you can use the number before the brackets, but this value must be reduced by two units. "temperature" (offset heating curve) in menu 1.1, set in these cases to -1.



Caution

The map values are usually a good starting point and are intended to provide an approximate room temperature of 20 °C. The values can be adjusted later if necessary.

Examples of basic values selection:

- House with low temperature* radiator systems
London = Area 15 (8).
Set 15 in menu 1.9.1, "heating curve" and -2 in menu 1.1 "temperature" (offset of heating curve).
- House with under floor heating** installed in a concrete floor structure
London = Area 15 (8).
Set 8 in menu 1.9.1, "heating curve" and -2 in menu 1.1 "temperature" (offset of heating curve).
- Houses with under floor heating** installed in a timber floor structure
London = Area 15 (8).
Set 13 (see point three in the list above) in menu 1.9.1, "heating curve" and -1 in menu 1.1 "temperature" (offset of heating curve).



Caution

An increase in the room temperature can be slowed by the thermostats for the radiators or under floor heating. Therefore, open the thermostat valves fully, except in those rooms where a cooler temperature is required, e.g. bedrooms.

* A low-temperature radiator system refers to a system where the supply temperature needs to be 55 °C on the coldest day.

** Under floor heating can be dimensioned very differently. The example above refers to a system where the supply temperature must be approx 35 – 40 °C resp. 45 – 50 °C on the coldest day.

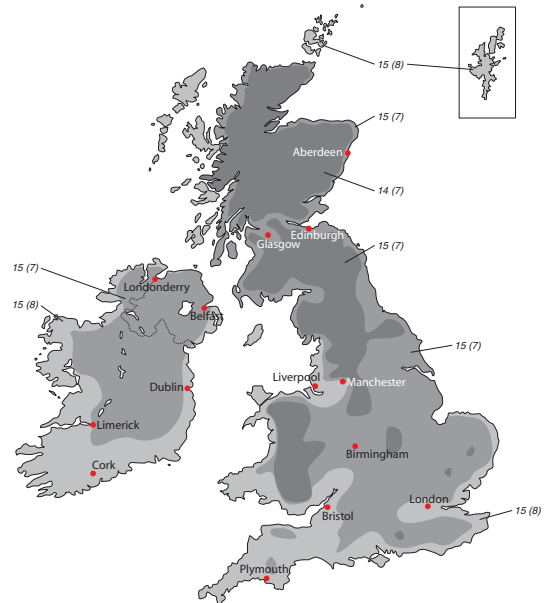

7 Control - Introduction

Display unit

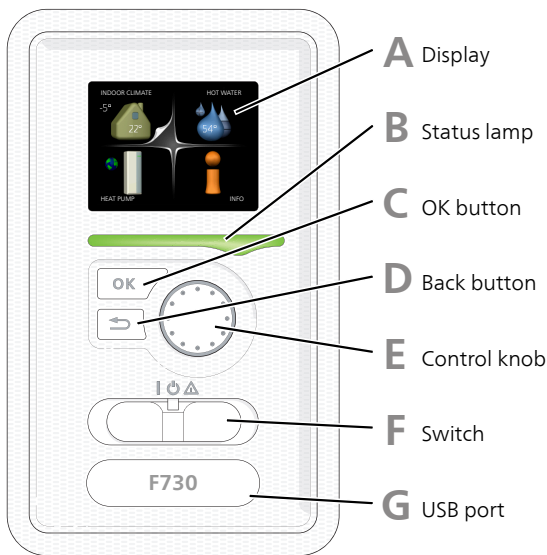

A Display

Instructions, settings and operational information are shown on the display. You can easily navigate between the different menus and options to set the comfort or obtain the information you require.

B Status lamp

The status lamp indicates the status of the heat pump. It:

- lights green during normal operation.
- lights yellow in emergency mode.
- lights red in the event of a deployed alarm.

C OK button

The OK button is used to:

- confirm selections of sub menus/options/set values/page in the start guide.

D Back button

The back button is used to:

- go back to the previous menu.
- change a setting that has not been confirmed.

E Control knob

The control knob can be turned to the right or left. You can:

- scroll in menus and between options.
- increase and decrease the values.
- change page in multiple page instructions (for example help text and service info).

F Switch (SF1)

The switch assumes three positions:

- On (I)
- Standby (⏻)
- Emergency mode (⚠) (see page 51)

Emergency mode must only be used in the event of a fault on the heat pump. In this mode, the compressor switches off and the immersion heater engages. The heat pump display is not illuminated and the status lamp illuminates yellow.

G USB port

The USB port is hidden beneath the plastic badge with the product name on it.

The USB port is used to update the software.

Visit <http://www.nibeuplink.com> and click the "Software" tab to download the latest software for your installation.

Menu system

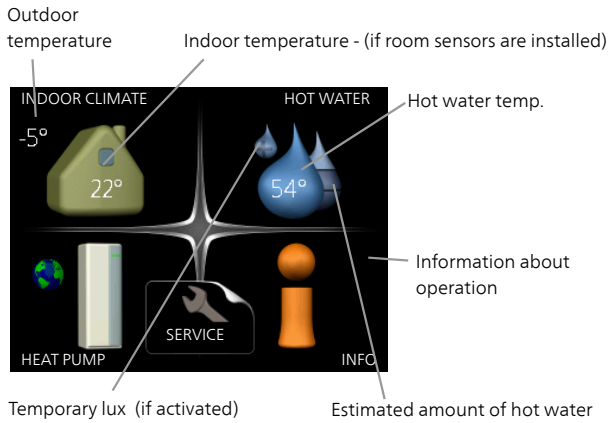

Menu 1 - INDOOR CLIMATE

Setting and scheduling the indoor climate. See information in the help menu or user manual.

Menu 2 - HOT WATER

Setting and scheduling hot water production. See information in the help menu or user manual.

Menu 3 - INFO

Display of temperature and other operating information and access to the alarm log. See information in the help menu or user manual.

Menu 4 - HEAT PUMP

Setting time, date, language, display, operating mode etc. See information in the help menu or user manual.

Menu 5 - SERVICE

Advanced settings. These settings are not available to the end user. The menu is visible when the Back button is pressed for 7 seconds when you are in the start menu. See page 44.

Symbols in the display

The following symbols can appear in the display during operation.

Symbol	Description
	This symbol appears by the information sign if there is information in menu 3.1 that you should note.
	These two symbols indicate whether the compressor or addition is blocked in F730. These can, for example, be blocked depending on which operating mode is selected in menu 4.2, if blocking is scheduled in menu 4.9.5 or if an alarm has occurred that blocks one of them. Blocking the compressor. Blocking additional heat.
	This symbol appears if periodic increase or lux mode for the hot water is activated.
	This symbol indicates whether "holiday setting" is active in 4.7.
	This symbol indicates whether F730 has contact with Uplink.
	This symbol indicates the actual speed of the fan if the speed has changed from the normal setting.

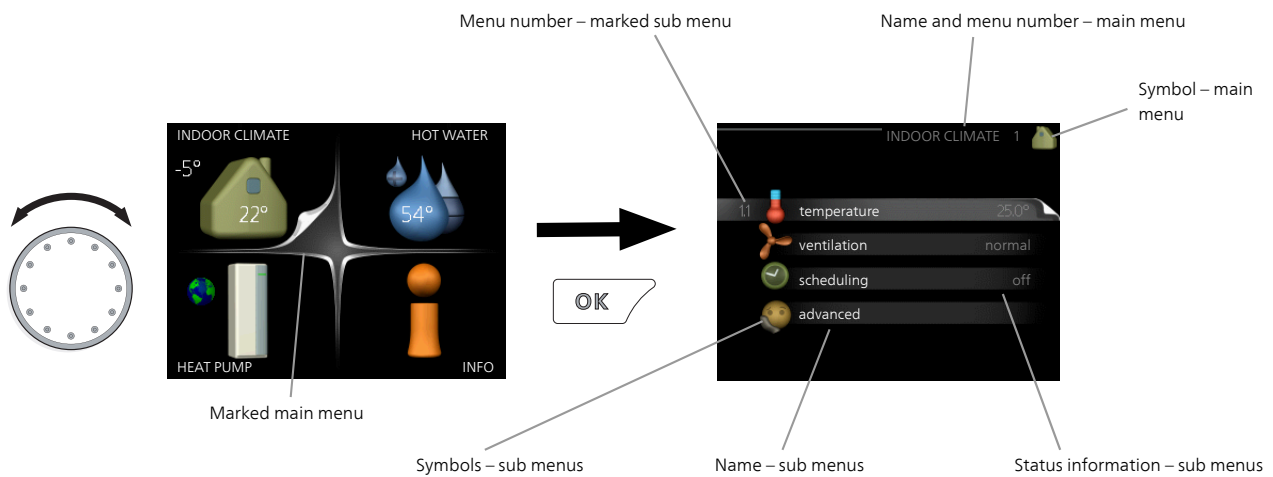

Operation

To move the cursor, turn the control knob to the left or the right. The marked position is white and/or has a turned up tab.



Selecting menu

To advance in the menu system select a main menu by marking it and then pressing the OK button. A new window then opens with sub menus.

Select one of the sub menus by marking it and then pressing the OK button.

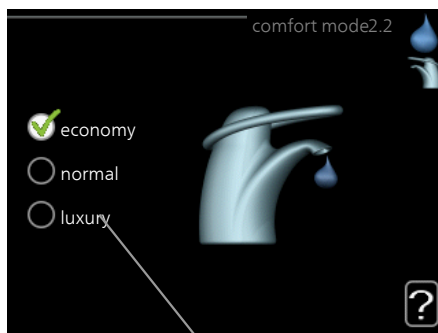

Selecting options



Alternative

In an options menu the current selected option is indicated by a green tick. 

To select another option:



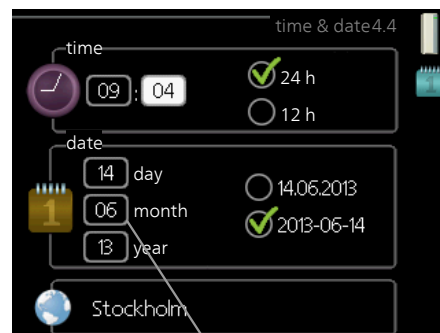

1. Mark the applicable option. One of the options is pre-selected (white). 
2. Press the OK button to confirm the selected option. The selected option has a green tick. 

Setting a value



Values to be changed

To set a value:

1. Mark the value you want to set using the control knob. 
2. Press the OK button. The background of the value becomes green, which means that you have accessed the setting mode. 
3. Turn the control knob to the right to increase the value and to the left to reduce the value. 
4. Press the OK button to confirm the value you have set. To change and return to the original value, press the Back button. 

Use the virtual keyboard

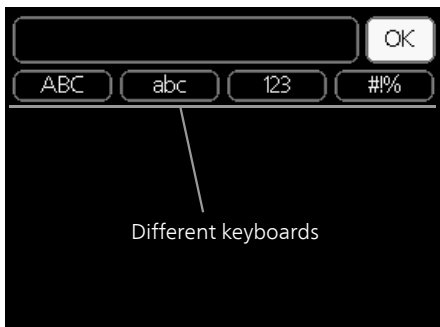

In some menus where text may require entering, a virtual keyboard is available.

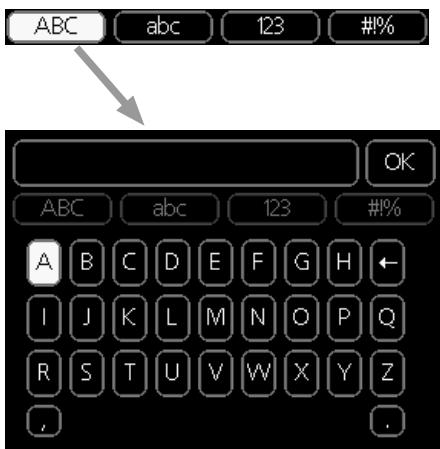

Depending on the menu, you can gain access to different character sets which you can select using the control knob. To change character table, press the Back button. If a menu only has one character set the keyboard is displayed directly.

When you have finished writing, mark "OK" and press the OK button.

Scroll through the windows

A menu can consist of several windows. Turn the control knob to scroll between the windows.



Current menu window Number of windows in the menu

Scroll through the windows in the start guide



Arrows to scroll through window in start guide

1. Turn the control knob until one of the arrows in the top left corner (at the page number) has been marked.
2. Press the OK button to skip between the steps in the start guide.

Help menu



In many menus there is a symbol that indicates that extra help is available.

To access the help text:

1. Use the control knob to select the help symbol.
2. Press the OK button.

The help text often consists of several windows that you can scroll between using the control knob.

8 Control - Menus

Menu 1 - INDOOR CLIMATE

Overview

1 - INDOOR CLIMATE	1.1 - temperature	
	1.2 - ventilation	
	1.3 - scheduling	1.3.1 - heating
		1.3.3 - ventilation
	1.9 - advanced	1.9.1.1 - heating curve
		1.9.2 - external adjustment
		1.9.3 - min. flow line temp.
		1.9.4 - room sensor settings
		1.9.6 - fan return time
		1.9.7 - own curve
	1.9.8 - point offset	
	1.9.9 - night cooling	

Menu 2 - HOT WATER

Overview

2 - HOT WATER	2.1 - temporary lux	
	2.2 - comfort mode	
	2.3 - scheduling	
	2.9 - advanced	2.9.1 - periodic increase
		2.9.2 - hot water recirc. *

* Accessory needed.

Menu 3 - INFO

Overview

3 - INFO	3.1 - service info
	3.2 - compressor info
	3.3 - add. heat info
	3.4 - alarm log
	3.5 - indoor temp. log

Menu 4 - HEAT PUMP

Overview

4 - HEAT PUMP	4.1 - plus functions *	4.1.3 - internet	4.1.3.1 - Uplink
			4.1.3.8 - tcp/ip settings
			4.1.3.9 - proxy settings
		4.1.4 - sms *	
		4.1.5 - SG Ready	
		4.1.6 - smart price adaption™	
		4.1.7 - smart home	
		Menu 4.1.10 – solar electricity *	
	4.2 - op. mode		
	4.3 - my icons		
	4.4 - time & date		
	4.6 - language		
	4.7 - holiday setting		
	4.9 - advanced	4.9.1 - op. prioritisation	
		4.9.2 - auto mode setting	
		4.9.3 - degree minute setting	
		4.9.4 - factory setting user	
		4.9.5 - schedule blocking	

* Accessory needed.

Menu 5 - SERVICE

Overview

5 - SERVICE	5.1 - operating settings	5.1.1 - hot water settings
		5.1.2 - max flow line temperature
		5.1.3 - max diff flow line temp.
		5.1.4 - alarm actions
		5.1.5 - fan sp. exhaust air
		5.1.10 - op. mod heat med pump
		5.1.11 - pump speed heating medium
		5.1.12 - internal electrical addition
		5.1.14 - flow set. climate system
		5.1.24 - blockFreq
		5.1.25 - time filter alarm
	5.2 - system settings	
	5.3 - accessory settings	5.3.3 - extra climate system *
		5.3.11 - modbus *
		5.3.17 - outdoor air mixing
	5.4 - soft in/outputs	
	5.5 - factory setting service	
	5.6 - forced control	
	5.7 - start guide	
	5.8 - quick start	
	5.9 - floor drying function	
	5.10 - change log	
	5.12 - country	

* Accessory needed.

Go to the main menu and hold the Back button in for 7 seconds to access the Service menu.

Sub-menus

Menu **SERVICE** has orange text and is intended for the advanced user. This menu has several sub-menus. Status information for the relevant menu can be found on the display to the right of the menus.

operating settings Operating settings for the heat pump.

system settings System settings for the heat pump, activating accessories etc.

accessory settings Operational settings for different accessories.

soft in/outputs Setting software controlled in and outputs on the input circuit board (AA3).

factory setting service Total reset of all settings (including settings available to the user) to default values.

forced control Forced control of the different components in the heat pump.

start guide Manual start of the start guide which is run the first time the heat pump is started.

quick start Quick starting the compressor.



NOTE

Incorrect settings in the service menus can damage the heat pump.

Menu 5.1 - operating settings

Operating settings can be made for the heat pump in the sub menus.

Menu 5.1.1 - hot water settings

economy

Setting range start temp. economy: 5 - 55 °C

Factory setting start temp. economy : 42 °C

Setting range stop temp. economy: 5 - 60 °C

Factory setting stop temp. economy : 46 °C

normal

Setting range start temp. normal: 5 - 60 °C

Factory setting start temp. normal : 46 °C

Setting range stop temp. normal: 5 - 65 °C

Factory setting stop temp. normal : 50 °C

luxury

Setting range start temp. lux: 5 - 70 °C

Factory setting start temp. lux : 49 °C

Setting range stop temp. lux: 5 - 70 °C

Factory setting stop temp. lux : 53 °C

stop temp. per. increase

Setting range: 55 – 70 °C

Factory setting: 55 °C

Here you set the start and stop temperature of the hot water for the different comfort options in menu 2.2 as well as the stop temperature for periodic increase in menu 2.9.1.

With "high power" activated, the hot water is charged with greater power than standard mode and therefore has a faster recharging time.

Menu 5.1.2 - max flow line temperature

climate system

Setting range: 20-70 °C

Default value: 60 °C

Set the maximum supply temperature for the climate system here. If the installation has more than one climate system, individual maximum supply temperatures can be set for each system. Climate systems 2 - 8 cannot be set to a higher max supply temperature than climate system 1.



Caution

Underfloor heating systems are normally **max flow line temperature** set between 35 and 45 °C.

Check the max floor temperature with your floor supplier.

Menu 5.1.3 - max diff flow line temp.

max diff compressor

Setting range: 1 – 25 °C

Default value: 10 °C

max diff addition

Setting range: 1 – 24 °C

Default value: 7 °C

Here you set the maximum permitted difference between the calculated and actual supply temperature during compressor respectively add. heat mode. Max diff. additional heat can never exceed max diff. compressor

max diff compressor

If the current supply temperature **exceeds** the calculated flow with set value, the degree minute value is set to 0. The compressor in the heat pump stops when there is only a heating demand.

max diff addition

If "addition" is selected and activated in menu 4.2 and the present supply temp **exceeds** the calculated with set value, the additional heat is forced to stop.

Menu 5.1.4 - alarm actions

Select how you want the heat pump to alert you that there is an alarm in the display here.

The different alternatives are that the heat pump stops producing hot water (default setting) and/or reduces the room temperature.



Caution

If no alarm action is selected, it can result in higher energy consumption in the event of an alarm.

Menu 5.1.5 - fan sp. exhaust air

normal and speed 1-4

Setting range: 0 – 100 %

Set the speed for the five different selectable speeds for the fan here. You can also select "adjusting ventilation" and "fan synch. operation".

adjusting ventilation

Tick "adjusting ventilation" in conjunction with ventilation adjustment. The selection is active for as long as you remain in the menu but deactivates when you leave the menu.

fan synch. operation

Select whether the fan is to maintain the same speed, regardless of whether the compressor is operating or not, or alternatively run at different speeds. If the function is activated, fan speed 2 applies when the compressor is not in operation, and normal fan speed applies when the compressor is in operation.



Caution

An incorrectly set ventilation flow can damage the house and may also increase energy consumption.

Menu 5.1.5.1 - adjusting ventilation

fan speed

Setting range: 0-100 %

Factory setting: the value selected in "normal" in menu 5.1.5.

actual air flow

Setting range: 1 – 400 m³/h

Factory setting: 0 m³/h

Here, you set the air flow and adjust the fan speed at ventilation adjustment.

"adjusting ventilation": Activate this function while the ventilation is being adjusted.

"fan speed": Here you can adjust the fan speed while "adjusting ventilation" is activated.



NOTE

If the fan speed is too high during adjustment, information that it needs to be reduced is given at the bottom of the page.

"actual air flow": Here, you set the real air flow as measured during the ventilation adjustment.



NOTE

When this setting is made, it is important that the ventilation flow is in a stable condition.

The function is deactivated when you exit the menu.

Menu 5.1.10 - op. mod heat med pump

op. mode

Setting range: auto, intermittent

Default value: auto

Default value: intermittent

Set the operating mode of the heating medium pump here.

auto: The heating medium pump runs according to the current operating mode for F730.

intermittent: The heating medium pump starts approx. 20 seconds before and stops at the same time as the compressor.

Menu 5.1.11 - pump speed heating medium

heating

Setting range: 1 - 100 %

Factory setting: 70 %

hot water

Setting range: 1 - 100 %

Factory setting: 70 %

wait mode

Setting range: 1 - 100 %

Default values: 30 %

max. allowed speed

Setting range: 50 - 100 %

Default values: 100 %

Here you set whether the heating medium pump's speed is to be regulated automatically or manually during heating and hot water. Select "auto" if the speed of the heating medium pump is to be regulated automatically (factory setting) for optimal operation. Select manual if you want to set the heating medium pump speed yourself, during heating and hot water.

If "auto" is activated for heating operation or hot water you can also make the setting "max. allowed speed", which restricts the heating medium pump and does not allow it to run at a higher speed than the set value.

"wait mode" means operating mode heating for the heating medium pump but when the heat pump neither has a need for compressor operation nor electrical addition and slows down.

Menu 5.1.12 - internal electrical addition

set max electrical add.

Setting range: 0.0 - 3.5 kW

Default values: 3.5 kW

max. set electrical output (SG Ready)

Setting range: 0 - 6.5 kW

Default values: 6.5 kW

fuse size

Setting range: 1 - 200 A

Factory setting: 16 A

transformation ratio

Setting range: 300 - 3000

Factory setting: 300

Here you set the max. electrical output of the internal electric additional heat in F730 during normal operation and overcapacity mode (SG Ready), as well as the fuse size and transformer ratio for the installation. The transformer ratio is the factor that is used to convert the metered voltage to current.

Menu 5.1.14 - flow set. climate system

presettings

Setting range: radiator, floor heat., rad. + floor heat., DOT °C

Default value: radiator

Setting range DOT: -40.0 – 20.0 °C

Factory setting DOT: -18.0 °C

own setting

Setting range dT at DOT: 0.0 – 25.0

Factory setting dT at DOT: 10.0

Setting range DOT: -40.0 – 20.0 °C

Factory setting DOT: -18.0 °C

The type of heating distribution system the heating medium pump (GP1) works towards is set here.

dT at DOT is the difference in degrees between flow and return temperatures at dimensioned outdoor temperature.

Menu 5.1.24 - blockFreq

from frequency

Setting range: 20 - 115 Hz

Factory setting: 20 Hz

Maximum setting range: 50 Hz.

to frequency

Setting range: 25 - 120 Hz

Factory setting: 25 Hz

Maximum setting range: 50 Hz.

Here you can set frequencies that are not to be permitted for the compressor. It is possible to restrict two different frequencies. Each frequency is restricted to between 3 and 50 Hz.



NOTE

A large blocked frequency range can cause the compressor to run jerkily.



NOTE

Blocking peak output in F730 can lead to reduced savings.

Menu 5.1.25 - time filter alarm

months btwn filter alarms

Setting range: 1 – 24

Factory setting: 3

Here you set the number of months between alarms for a reminder to clean the filter in F730.

Menu 5.2 - system settings

Inform the heat pump which accessories are installed here.

There are two ways of activating connected accessories. You can either mark the alternative in the list or use the automatic function "search installed acc."

search installed acc.

Mark "search installed acc." and press the OK button to automatically find connected accessories for F730.

Menu 5.3 - accessory settings

The operating settings for accessories that are installed and activated are made in the sub-menus for this.

This is also where you activate the outdoor air damper.

Menu 5.3.3 - extra climate system

mixing valve amplifier

Setting range: 0.1 – 10.0

Default value: 1.0

mixing valve step delay

Setting range: 10 – 300 s

Default values: 30 s

The shunt amplification and shunt waiting time for the different extra climate systems that are installed are also set here.

See the accessory installation instructions for function description.

Menu 5.3.11 - modbus

address

Factory setting: address 1

From and including Modbus 40 version 10 the address can be set between 1 - 247. Earlier versions have a static address.

See the accessory installation instructions for function description.

Menu 5.3.17 - outdoor air mixing

max. outdoor air temp.

Setting range: 0 - 40 °C

Factory setting: 10 °C

fan speed outdoor air

Setting range: 50 - 100 %

Factory setting: 100 %

Activate adjusting the ventilation for the outdoor air mixture here. During the time that the adjustment is active the fan runs according to the set value "fan speed outdoor air" and the outdoor air damper is open.

max. outdoor air temp.: Maximum limit for when outdoor mixing function can be active.

fan speed outdoor air: The speed the fan runs at when the outdoor air mixing function is active.

See section "Setting the ventilation" on page 35 for description of functions.

Menu 5.4 - soft in/outputs

Here you can select the input/output on the input board (AA3) to which the external switch function (page 29) is to be connected.

Selectable inputs on terminal block AUX 1-5 (AA3-X6:9-18) and output AA3-X7 on the input board.

Menu 5.5 - factory setting service

All settings can be reset (including settings available to the user) to default values here.



NOTE

When resetting, the start guide is displayed the next time the heat pump is restarted.

Menu 5.6 - forced control

You can force control the different components in the heat pump and any connected accessories here.

Menu 5.7 - start guide

When the heat pump is started for the first time the start guide starts automatically. Start it manually here.

See page 34 for more information about the start guide.

Menu 5.8 - quick start

It is possible to start the compressor from here.



Caution

There must be a heating or hot water demand to start the compressor.



Caution

Do not quick start the compressor too many times over a short period of time as this may damage the compressor and its surrounding equipment.

Menu 5.9 - floor drying function

length of period 1 – 7

Setting range: 0 – 30 days

Factory setting, period 1 – 3, 5 – 7: 2 days

Factory setting, period 4: 3 days

temp. period 1 – 7

Setting range: 15 – 70 °C

Default value:

temp. period 1	20 °C
temp. period 2	30 °C
temp. period 3	40 °C
temp. period 4	45 C
temp. period 5	40 °C
temp. period 6	30 °C
temp. period 7	20 °C

Set the function for under floor drying here.

You can set up to seven period times with different calculated flow temperatures. If less than seven periods are to be used, set the remaining period times to 0 days.

Mark the active window to activate the underfloor drying function. A counter at the bottom shows the number of days the function has been active.



TIP

If operating mode "add. heat only" is to be used, select it in menu 4.2.

Menu 5.10 - change log

Read off any previous changes to the control system here.

The date, time and ID no. (unique to certain settings) and the new set value is shown for every change.



NOTE

The change log is saved at restart and remains unchanged after factory setting.

5.12 - country

Select here where the product was installed. This allows access to country specific settings in your product.

Language settings can be made regardless of this selection.



NOTE

This option locks after 24 hours, restart of display or program updating.

9 Service

NOTE

F730 must be serviced once a year by competent and qualified personnel, such as a NIBE a service engineer or other qualified professional. When replacing components on F730 only replacement parts from NIBE may be used.

NOTE

Take the necessary safety precautions. Ensure that the heat pump is not connected to the power prior to servicing or maintenance work.

NOTE

If an electrical connection has been disconnected and is connected, ground must be checked using a suitable multimeter.

NOTE

An immersion heater without a temperature limiter is not allowed to be installed.

NOTE

Inspection of the water heater can be carried out via the flange located at the top of the water heater using an inspection instrument such as an endoscope.

NOTE

After servicing, complete the relevant Service Interval Record section of the Benchmark Checklist located at the back of this document. Completion of the Service Interval Record is a condition of warranty. For full terms and conditions of warranty, please see our website www.nibe.co.uk.

Maintenance

Cleaning the overflow cup/floor drain

Regularly check that the overflow cup and any floor drains are not blocked; water must be able to run through freely. Clean, if necessary.

NOTE

If the overflow cup or floor drain is blocked, water can run over onto the floor of the installation area. To prevent damage to the building the floor coating must be considered. A waterproof floor or floor membrane is recommended.

General inspection

Check the following:

1. Condition of casing.
2. Electrical connections.
3. Pipe connections.
4. Alarm log.

Correct any fault before continuing.

Water heater

Check the following:

1. Hot water start and stop temperature.
2. Pressure controlled bypass valve.
3. T&P valve.
4. Overflow pipe.
5. Pressure expansion vessel.

Correct any fault before continuing.

Hot water settings

Check the following:

1. Hot water start and stop temperature.
2. Hot water mode.

Correct any fault before continuing.

Climate system

Check the following:

1. Climate system start and stop temperature.
2. Heating curve settings.
3. Function of the room sensor (if installed).
4. Limiting valve settings.
5. System pressure.
6. Flow and return temperature. The difference must be 5 - 10 °C

Correct any fault before continuing.

Ventilation system

Check the following:

1. The air filter. Clean or replace if necessary.
2. Any dirt on the fan. Clean if necessary.
3. Ensure that the ventilation openings are not blocked.
4. The airflow. Adjust if necessary.
5. Ensure that the damper motor is not blocked.

Correct any fault before continuing.

Safety valves

F730 has three safety valves, two for the water heater and one for the climate system.

The function of the safety valves must be checked regularly. The valves are accessed via the service hatch. Perform checks as follows:

1. Open the valve by turning the knob anti-clockwise carefully.
2. Check that water flows through the valve.
3. Close the valve by releasing it. If it does not close automatically when released, turn it anti-clockwise slightly.
4. The climate system may need to be refilled after checking the safety valve, see the section "Filling the climate system".

Service actions

Emergency mode

Emergency mode is used in event of operational interference and in conjunction with service.

Emergency mode is activated by setting switch (SF1) in mode "▲". This means that:

- The status lamp illuminates yellow.
- The display is not lit and the control computer is not connected.
- The temperature at the immersion heater is controlled by the thermostat (FD1-BT30). It can be set either to 35 or 45 °C.
- The compressor is off and only the fan, heating medium pump and the electric additional heat are active. The additional heat power in emergency mode is set in the immersion heater card (AA1). See page 28 for instructions.

Draining the water heater

The water heater can be drained via the safety valve (FL1) or via the overflow cup (WM1).

1. Disconnect the overflow pipe from the safety valve (FL1) and connect a hose to a draining pump instead. If a draining pump is not available, the water can be released into the overflow cup (WM1).
2. Open the safety valve (FL1).
3. Open a hot water tap to let air into the system. If this is not sufficient, detach the pipe connection (XL4) on the hot water side and ensure that air is entering.

Cleaning the water heater

To clean the water heater, remove the upper panel and the insulation. Then open the flange for easy access.

Draining the climate system

In order to carry out service on the climate system, it may be easier to drain the system first.



NOTE

There may be some hot water when draining the heating medium side/climate system. There is a risk of scalding.

The hot water can be drained through the safety valve (FL2) via the overflow cup (WM1) or through a hose that is connected to the safety valve's (FL2) or the drain valve's (XL10) outlet.

1. Open the safety valve (FL2) or the drain valve (XL10).
2. Set the vent valves for the climate system (QM20), (QM22), (QM24), (QM26) in the open position for air supply.



NOTE

The heat pump should not, after draining, be exposed to risk of freezing because a certain of water remains in the coil.

Temperature sensor data

Temperature (°C)	Resistance (kOhm)	Voltage (VDC)
-40	351.0	3.256
-35	251.6	3.240
-30	182.5	3.218
-25	133.8	3.189
-20	99.22	3.150
-15	74.32	3.105
-10	56.20	3.047
-5	42.89	2.976
0	33.02	2.889
5	25.61	2.789
10	20.02	2.673
15	15.77	2.541
20	12.51	2.399
25	10.00	2.245
30	8.045	2.083
35	6.514	1.916
40	5.306	1.752
45	4.348	1.587
50	3.583	1.426
55	2.968	1.278
60	2.467	1.136
65	2.068	1.007
70	1.739	0.891
75	1.469	0.785
80	1.246	0.691
85	1.061	0.607
90	0.908	0.533
95	0.779	0.469
100	0.672	0.414

USB service outlet

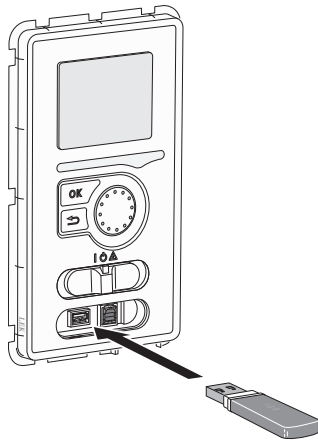

The display unit is equipped with a USB socket that can be used to update the software, save logged information and handle the settings in F730.

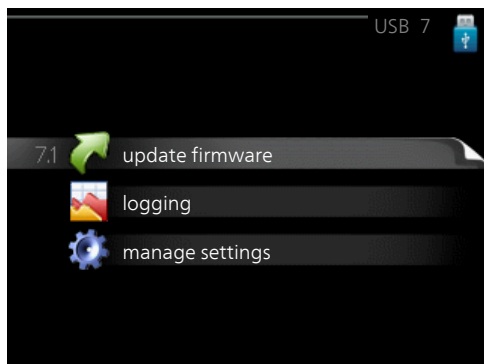
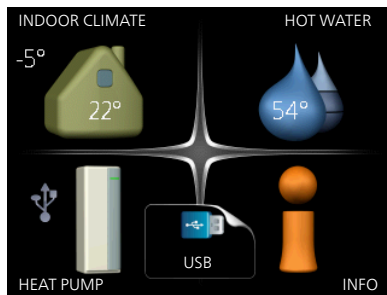

When a USB memory is connected a new menu (menu 7) appears in the display.

Menu 7.1 - update firmware

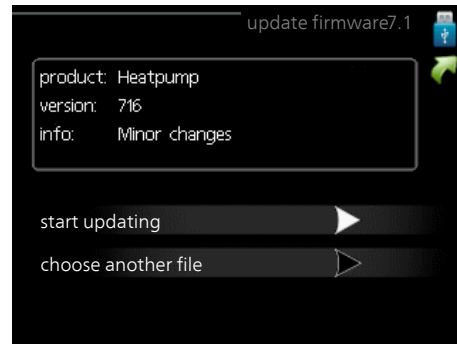

This allows you to update the software in F730.



NOTE

For the following functions to work the USB memory must contain files with software for F730 from NIBE.

The fact box at the top of the display shows information (always in English) of the most probable update that the update software has selected from the USB memory.

This information states which product the software is intended for, the software version and general information about them. If you wish to select another file than the one selected, the correct file can be selected by "choose another file".

start updating

Select "start updating" if you want to start the update. You are asked whether you really want to update the software. Respond "yes" to continue or "no" to undo.

If you responded "yes" to the previous question the update starts and you can now follow the progress of the update on the display. When the update is complete F730 restarts.



NOTE

A software update does not reset the menu settings in F730.



NOTE

If the update is interrupted before it is complete (for example power cut etc.), the software can be reset to the previous version if the OK button is held in during start up until the green lamp starts to illuminate (takes about 10 seconds).

choose another file



Select "choose another file" if you do not want to use the suggested software. When you scroll through the files, information about the marked software is shown in a fact box just as before. When you have selected a file with the OK button you will return to the previous page (menu 7.1) where you can choose to start the update.

Menu 7.2 - logging

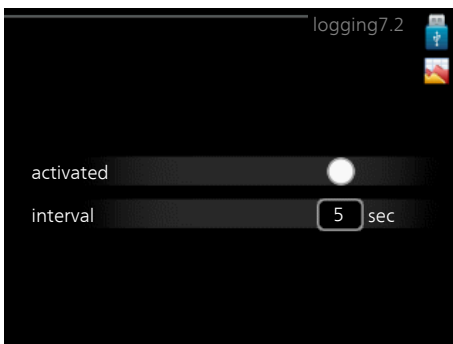

Setting range: 1 s – 60 min
Factory setting range: 5 s

Here you can choose how current measurement values from F730 should be saved onto a log file on the USB memory.

1. Set the desired interval between loggings.
2. Tick "activated".
3. The present values from F730 are saved in a file in the USB memory at the set interval until "activated" is unticked.

NOTE
Untick "activated" before removing the USB memory.

Menu 7.3 - manage settings

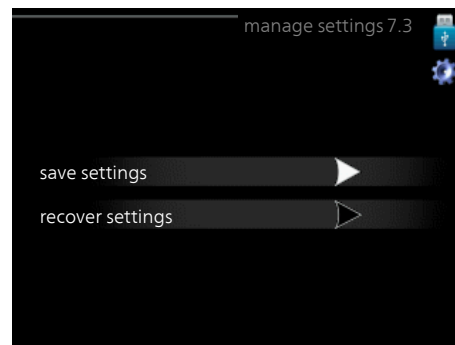

Here you can manage (save as or retrieve from) all the menu settings (user and service menus) in F730 with a USB memory.

Via "save settings" you save the menu settings to the USB memory in order to restore them later or to copy the settings to another F730.

NOTE
When you save the menu settings to the USB memory you replace any previously saved settings on the USB memory.

Via "recover settings" you reset all menu settings from the USB memory.

NOTE
Reset of the menu settings from the USB memory cannot be undone.

10 Disturbances in comfort

In most cases, the heat pump notes operational interference (operational interference can lead to disturbance in comfort) and indicates this with alarms and shows action instructions in the display.

Info-menu

All the heat pump measurement values are gathered under menu 3.1 in the heat pump menu system. Looking through the values in this menu can often simplify finding the source of the fault. See help menu or user manual for more information about menu 3.1.

Manage alarm

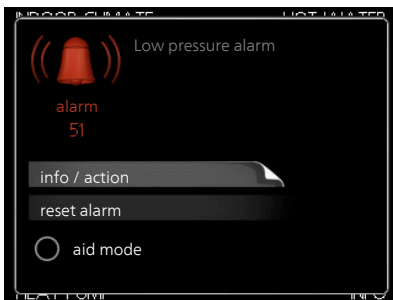

In the event of an alarm, some kind of malfunction has occurred, which is indicated by the status lamp changing from green continuously to red continuously. In addition, an alarm bell appears in the information window.

Alarm

In the event of an alarm with a red status lamp a malfunction has occurred that the heat pump cannot remedy itself. In the display, by turning the control knob and pressing the OK button, you can see the type of alarm it is and reset it. You can also choose to set the heat pump to aid mode.

info / action Here you can read what the alarm means and receive tips on what you can do to correct the problem that caused the alarm.

reset alarm In most cases it is enough to select "reset alarm" to correct the problem that caused the alarm. If a green light illuminates after selecting "reset alarm" the alarm has been remedied. If a red light is still visible and a menu called "alarm" is visible in the display, the problem that caused the alarm remains. If the alarm disappears and then returns, see the section "Troubleshooting".

aid mode "aid mode" is a type of emergency mode. This means that the heat pump produces heat and/or hot water despite there being some kind of problem. This can mean that the heat pump's compressor is not running. In this case the immersion heater produces heat and/or hot water.



NOTE

To select aid mode an alarm action must be selected in the menu 5.1.4.



Caution

Selecting "aid mode" is not the same as correcting the problem that caused the alarm. The status lamp will therefore continue to be red.

Troubleshooting

If the operational interference is not shown in the display the following tips can be used:

Basic actions

Start by checking the following possible fault sources:

- The switch's (SF1) position.
- Group and main fuses of the accommodation.
- Earth-fault breaker.
- The heat pump's miniature circuit breaker (FA1).
- The heat pump's temperature limiter (FD1).

Low hot water temperature or a lack of hot water

- Closed or throttled externally mounted filler valve for the water heater.
 - Open the valve.
- Heat pump in incorrect operating mode.
 - Enter menu 4.2. If mode "auto" is selected, select a higher value on "stop additional heat" in menu 4.9.2.
 - If mode "manual" is selected, select "addition".
- Large hot water consumption.
 - Wait until the hot water has heated up. Temporarily increased hot water capacity (temporary lux) can be activated in menu 2.1.
- Too low hot water setting.
 - Enter menu 2.2 and select a higher comfort mode.
- Too low or no operating prioritisation of hot water.
 - Enter menu 4.9.1 and increase the time for when hot water is to be prioritised. Note that if the time for hot water is increased, the time for heating production is reduced, which can give lower/uneven room temperatures.

Low room temperature

- Closed thermostats in several rooms.
 - See the "Saving tips" section in the User manual for more detailed information about how to best set the thermostats.
- Heat pump in incorrect operating mode.
 - Enter menu 4.2. If mode "auto" is selected, select a higher value on "stop heating" in menu 4.9.2.
 - If mode "manual" is selected, select "heating". If this is not enough, select "addition".

- Too low set value on the automatic heating control.
 - Enter menu 1.1 "temperature" and adjust the offset heating curve up. If the room temperature is only low in cold weather the curve slope in menu 1.9.1 "heating curve" needs adjusting up.
- Too low or no operating prioritisation of heat.
 - Enter menu 4.9.1 and increase the time for when heating is to be prioritised. Note that if the time for heating is increased the time for hot water production is reduced, which can give smaller amounts of hot water.
- "comfort mode" "luxury" selected in combination with large hot water outlet.
 - Enter menu 2.2 and select "economy" or "normal".
- "Holiday mode" activated in menu 4.7.
 - Enter menu 4.7 and select "Off".
- External switch for changing the room heating activated.
 - Check any external switches.
- The heating medium pump (GP1 has stopped).
- Air in the heating system.
 - Vent the heating system (see page 33).
- Incorrect value set in menu 5.1.12.
 - Enter menu 5.1.12 and increase the value on "set max electrical add."

High room temperature

- Too high set value on the automatic heating control.
 - Enter menu 1.1 (temperature) and reduce the offset heating curve. If the room temperature is only high in cold weather the curve slope in menu 1.9.1 "heating curve" needs adjusting down.
- External switch for changing the room heating activated.
 - Check any external switches.

Low system pressure

- Not enough water in the heating system.
 - Top up the water in the heating system (see page 33).

Low or a lack of ventilation

- Filter (HQ10) blocked.
 - Clean or replace the filter.
- The ventilation is not adjusted.
 - Order/implement ventilation adjustment.
- Exhaust air device blocked or throttled down too much.
 - Check and clean the exhaust air devices.
- Fan speed in reduced mode.
 - Enter menu 1.2 and select "normal".
- External switch for changing the fan speed activated.
 - Check any external switches.

High or distracting ventilation

- Filter (HQ10) blocked.
 - Clean or replace the filter.
- The ventilation is not adjusted.
 - Order/implement ventilation adjustment.
- Fan speed in forced mode.
 - Enter menu 1.2 and select "normal".
- External switch for changing the fan speed activated.
 - Check any external switches.

The compressor does not start

- There is no heating requirement.
 - The heat pump does not call on heating nor hot water.
 - The heat pump defrosts.
- Compressor blocked due to the temperature conditions.
 - Wait until the temperature is within the product's working range.
- Minimum time between compressor starts has not been reached.
 - Wait 30 minutes and then check if the compressor has started.
- Alarm tripped.
 - Follow the display instructions.

11 Accessories

Communications module MODBUS 40

MODBUS 40 enables F730 to be controlled and monitored using a DUC (computer sub-centre) in the building. Communication is then performed using MODBUS-RTU.

Part no 067 144

Docking kit DEW 41

DEW 41 means that F730 can be connected to water heater VPB 200.

Part no. 067 537

Extra shunt group ECS 40/ECS 41

This accessory is used when F730 is installed in houses with two or more different heating systems that require different supply temperatures.

ECS 40 (Max 80 m²)

Part no 067 287

ECS 41 (approx. 80-250 m²)

Part no 067 288

Room unit RMU 40

RMU 40 means that control and monitoring of F730 can be carried out in a different part of your home to where it is located.

Part no 067 064

Splitter kit DKI 10

For split installation of F730.

Part no. 089 777

Top cabinet

Top cabinet that conceals the ventilation ducts and reduces the sound to the installation room by 1-2 dB(A).

Height 245 mm

Part no. 089 756

Height 445 mm

Part no. 067 522

Height 345 mm

Part no. 089 757

Height 385-635 mm

Part no. 089 758

Water heater/Accumulator tank

VPB

Water heater without immersion heater with charge coil. Requires docking kit.

VPB 200

Stainless steel Part no. 088 518

Part no. 088 516

VPB 300

Stainless steel Part no. 083 020

steel

12 Technical data

Dimensions and setting-out coordinates

F730 installed as one unit.

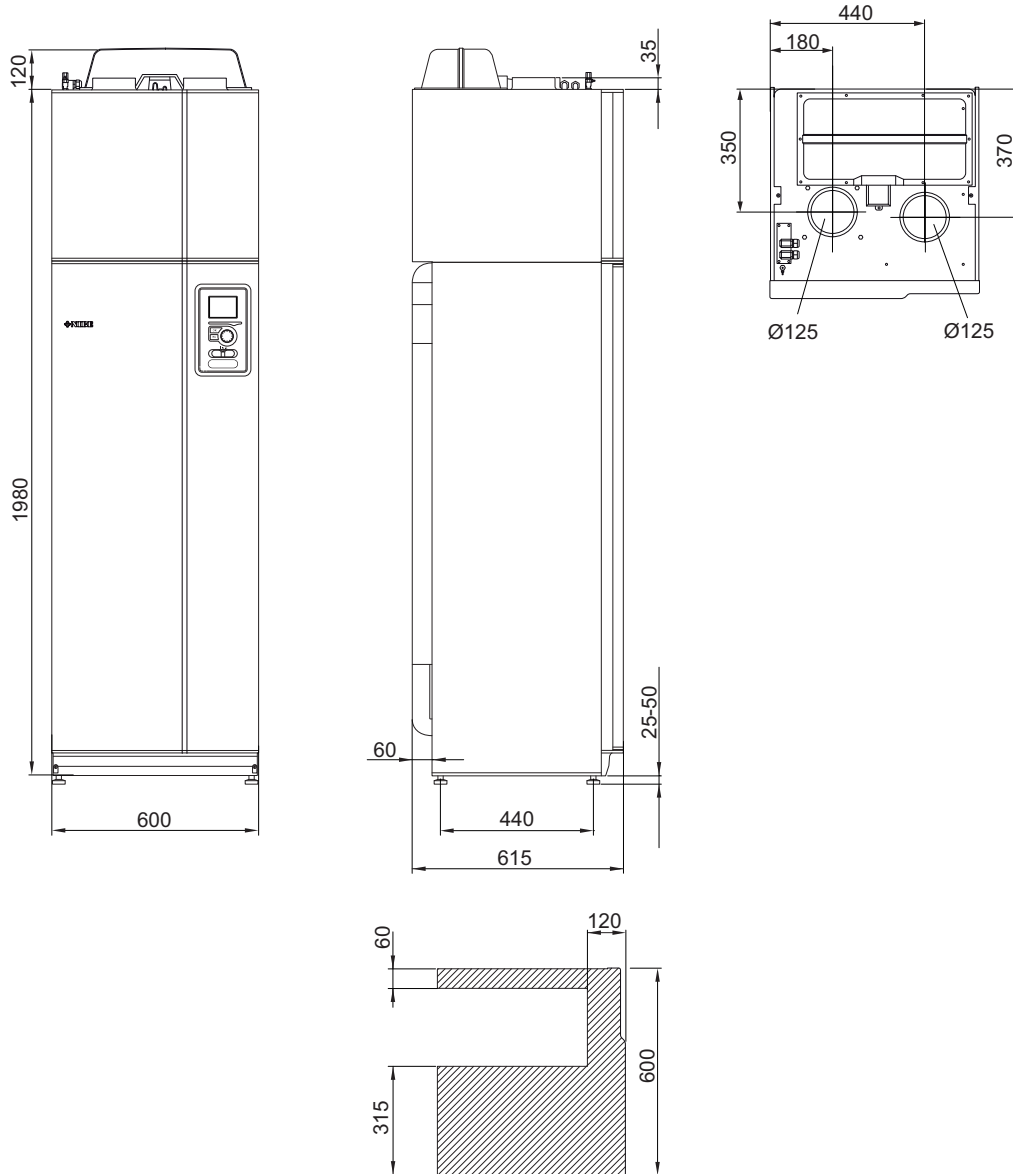

Avoid routing pipes through the marked area

F730 at separated installation.

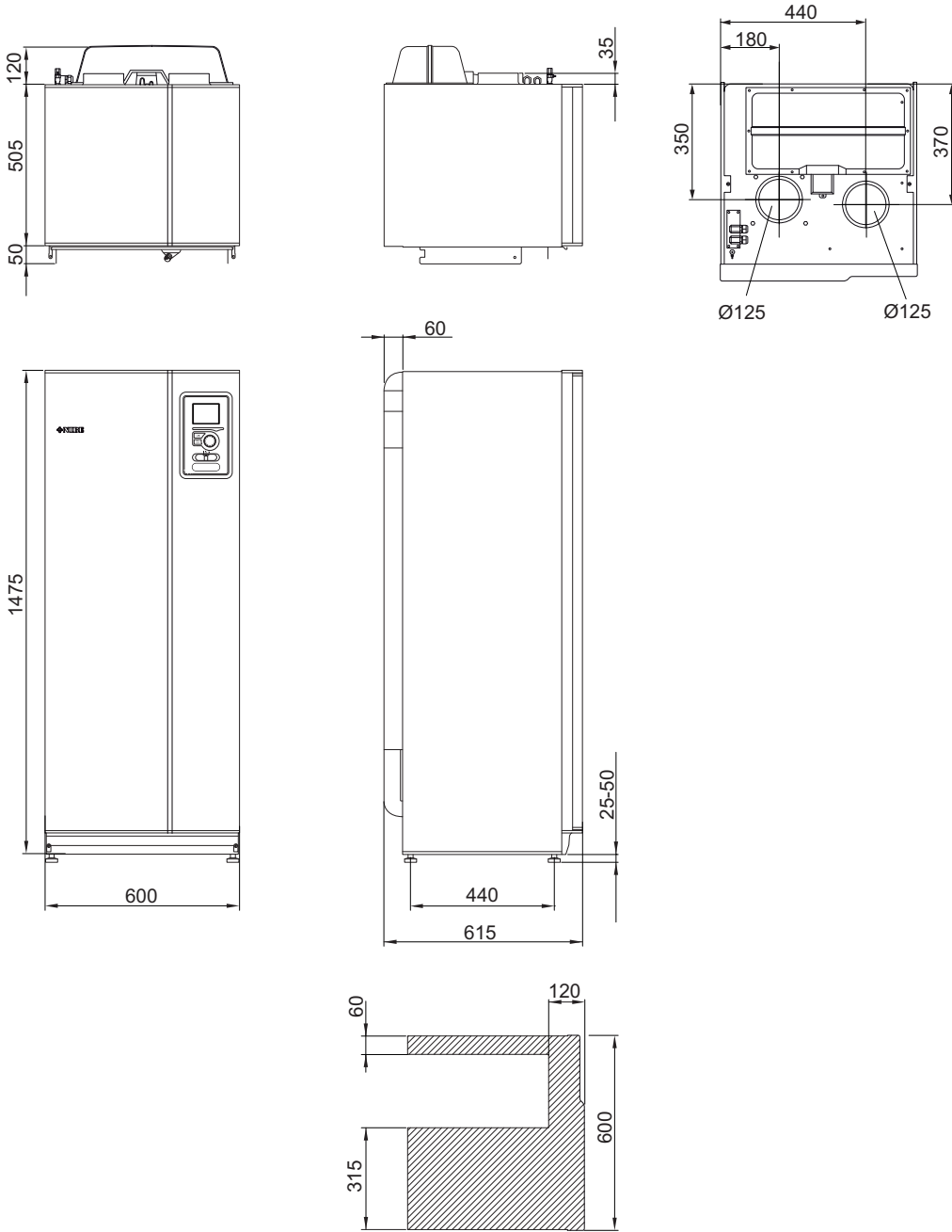

Avoid routing pipes through the marked area

Technical specifications



1x230 V		Stainless
<i>Output data according to EN 14 511</i>		
Specified heating output (P _H) ¹	kW	1.27
COP ¹		3.41
Specified heating output (P _H) ²	kW	3.41
COP ²		2.42
<i>Output data according to EN 14 825</i>		
Rated heating output (P _{designh})	kW	5
SCOP cold climate, 35 °C / 55 °C	kW	4.65 / 3.57
SCOP average climate, 35 °C / 55 °C	kW	4.35 / 3.38
SCOP warm climate, 35 °C / 55 °C	kW	4.44 / 3.40
<i>Additional power</i>		
Max power, immersion heater (factory setting)	kW	3.5 (3.5)
<i>Electrical data</i>		
Rated voltage	V	230 V ~ 50 Hz
Max operating current	A	28.3
Min. fuse rating	A	16
Drive output heating medium pump	W	4-76
Driving power exhaust air fan	W	25-140
Enclosure class		IP 21
<i>Refrigerant circuit</i>		
Type of refrigerant		R407C
GWP refrigerant		1774
Volume	kg	0.74
CO ₂ equivalent	ton	1.312
Cut-out value pressostat HP	MPa/bar	2.9 / 29.0
Cut-out value pressostat LP	MPa/bar	0.05 / 0.5
<i>Heating medium circuit</i>		
Opening pressure, safety valve	MPa/bar	0.25 / 2.5
Operating pressure (supply line)	MPa/bar	0.2 / 2.0
Max temperature, supply line (factory setting)	°C	70 (60)
<i>Ventilation</i>		
Min. airflow	l/s	21
<i>Sound effect level according to EN 12 102</i>		
Sound power level (L _{W(A)}) ³	dB(A)	40-55
<i>Sound pressure levels</i>		
Sound pressure level in the boiler room (L _{P(A)}) ⁴	dB(A)	36-51
<i>Pipe connections</i>		
Heating medium ext Ø	mm	22
Hot water ext Ø	mm	22
Cold water ext Ø	mm	22
Ventilation Ø	mm	125

Other 1x230 V		Stainless
<i>Water heater and heating section</i>		
Volume heating section	litre	10
Volume, hot water heater	litre	180
Max pressure in hot water heater	MPa/bar	0.65 / 6.5
<i>Capacity hot water heating according to EN 12 897</i>		
Maximum water supply pressure	MPa/bar	1.6 / 16
Operating pressure, tap water	MPa/bar	0.6 / 6.0
Expansion vessel, tap water, precharge pressure	MPa/bar	0.35 / 3.5
Volume expansion vessel (external)	litre	18
Pressure reduction valve, setting	MPa/bar	0.3 / 3.0
Max operating pressure of T&P-valve	MPa/bar	0.7 / 7.0
Max operating temperature T&P-valve	°C	95
Discharge capacity of T&P-valve	kW	25
Set opening pressure expansion valve tap water	MPa/bar	0.6 / 6.0
Cut out, temperature limiter	°C	80
Heating time 15 °C to 60 °C	h min	2 h 55 min
Capacity charge coil, 15 °C to 60 °C, primary flow 900 l/h	kW	2.9
Pressure drop at 900 l/h	kPa	15
Tap volume 40 °C ⁵	litre	168.2
Idle loss	kWh/24 h	2.02
<i>Dimensions and weight</i>		
Width	mm	600
Depth	mm	610
Height excl. inverter box, incl. feet	mm	2000 - 2030
Required ceiling height	mm	2,170
Net weight	kg	185
Mass unit, filled with water	kg	375
Part No.		066 017

¹A20(12)W45, exhaust air flow 42 l/s (150 m³/h) min compressor frequency

²A20(12)W45, exhaust air flow 42 l/s (150 m³/h) max compressor frequency

³The value varies with the selected fan curve. For more extensive sound data including sound to channels visit nibe.eu.

⁴ The value can vary with the room's damping capacity. These values apply at a damping of 4 dB.

⁵Comfort mode, normal

Energy labelling

Information sheet

Supplier		NIBE
Model		F730
Temperature application	°C	35 / 55
Declared load profile for water heating		L
Seasonal space heating energy efficiency class, average climate		A++ / A++
Water heating energy efficiency class, average climate		A
Rated heat output ($P_{designh}$), average climate	kW	5 / 5
Annual energy consumption space heating, average climate	kWh	2121 / 2756
Annual energy consumption water heating, average climate	kWh	1123
Seasonal space heating energy efficiency, average climate	%	172 / 132
Water heating energy efficiency, average climate	%	91
Sound power level L_{WA} indoors	dB	44
Rated heat output ($P_{designh}$), cold climate	kW	5 / 5
Rated heat output ($P_{designh}$), warm climate	kW	5 / 5
Annual energy consumption space heating, cold climate	kWh	2389 / 3105
Annual energy consumption water heating, cold climate	kWh	1123
Annual energy consumption space heating, warm climate	kWh	1359 / 1766
Annual energy consumption water heating, warm climate	kWh	1123
Seasonal space heating energy efficiency, cold climate	%	183 / 140
Water heating energy efficiency, cold climate	%	91
Seasonal space heating energy efficiency, warm climate	%	174 / 133
Water heating energy efficiency, warm climate	%	91
Sound power level L_{WA} outdoors	dB	-

Data for energy efficiency of the package

Model		F730
Temperature application	°C	35 / 55
Controller, class		VI
Controller, contribution to efficiency	%	4
Seasonal space heating energy efficiency of the package, average climate	%	176 / 136
Seasonal space heating energy efficiency class of the package, average climate		A+++ / A++
Seasonal space heating energy efficiency of the package, cold climate	%	187 / 144
Seasonal space heating energy efficiency of the package, warm climate	%	178 / 137

The reported efficiency of the package also takes the controller into account. If an external supplementary boiler or solar heating is added to the package, the overall efficiency of the package should be recalculated.

Technical documentation

Model				F730							
Type of heat pump				<input type="checkbox"/> Air-water <input checked="" type="checkbox"/> Exhaust-water <input type="checkbox"/> Brine-water <input type="checkbox"/> Water-water							
Low-temperature heat pump				<input type="checkbox"/> Yes <input checked="" type="checkbox"/> No							
Integrated immersion heater for additional heat				<input checked="" type="checkbox"/> Yes <input type="checkbox"/> No							
Heat pump combination heater				<input checked="" type="checkbox"/> Yes <input type="checkbox"/> No							
Climate				<input checked="" type="checkbox"/> Average <input type="checkbox"/> Cold <input type="checkbox"/> Warm							
Temperature application				<input checked="" type="checkbox"/> Average (55 °C) <input type="checkbox"/> Low (35 °C)							
Applied standards				EN14825, EN14511, EN16147, EN12102							
Rated heat output		Prated	4,5	kW	Seasonal space heating energy efficiency		η_s	132	%		
<i>Declared capacity for space heating at part load and at outdoor temperature T_j</i>				<i>Declared coefficient of performance for space heating at part load and at outdoor temperature T_j</i>							
$T_j = -7\text{ °C}$	Pdh	4.0	kW	$T_j = -7\text{ °C}$	COPd	2.3	-				
$T_j = +2\text{ °C}$	Pdh	2.4	kW	$T_j = +2\text{ °C}$	COPd	3.4	-				
$T_j = +7\text{ °C}$	Pdh	1.6	kW	$T_j = +7\text{ °C}$	COPd	4.4	-				
$T_j = +12\text{ °C}$	Pdh	1.7	kW	$T_j = +12\text{ °C}$	COPd	4.2	-				
$T_j = \text{biv}$	Pdh	4.0	kW	$T_j = \text{biv}$	COPd	2.3	-				
$T_j = \text{TOL}$	Pdh	3.6	kW	$T_j = \text{TOL}$	COPd	2.3	-				
$T_j = -15\text{ °C}$ (if TOL < -20 °C)	Pdh		kW	$T_j = -15\text{ °C}$ (if TOL < -20 °C)	COPd		-				
Bivalent temperature				T_{biv}	-7	°C	Min. outdoor air temperature		TOL	-10	°C
Cycling interval capacity				P _{cy}		kW	Cycling interval efficiency		COP _{cy}		-
Degradation coefficient				C _{dh}	0.97	-	Max supply temperature		WTOL	60	°C
<i>Power consumption in modes other than active mode</i>				<i>Additional heat</i>							
Off mode		P _{OFF}	0.003	kW	Rated heat output		P _{sup}	0.9	kW		
Thermostat-off mode		P _{TO}	0.02	kW							
Standby mode		P _{SB}	0.02	kW	Type of energy input		Electric				
Crankcase heater mode		P _{CK}	0.00	kW							
<i>Other items</i>											
Capacity control		Variable			Rated airflow (air-water)			180	m ³ /h		
Sound power level, indoors/outdoors		L _{WA}	44 / -	dB	Nominal heating medium flow				m ³ /h		
Annual energy consumption		Q _{HE}	2,750	kWh	Brine flow brine-water or water-water heat pumps				m ³ /h		
<i>For heat pump combination heater</i>											
Declared load profile for water heating				L		Water heating energy efficiency		η_{wh}	91	%	
Daily energy consumption		Q _{elec}	5.11	kWh	Daily fuel consumption		Q _{fuel}		kWh		
Annual energy consumption		AEC	1,123	kWh	Annual fuel consumption		AFC		GJ		
Contact information		NIBE Energy Systems – Box 14 – Hannabadsvägen 5 – 285 21 Markaryd – Sweden									

Electrical circuit diagram

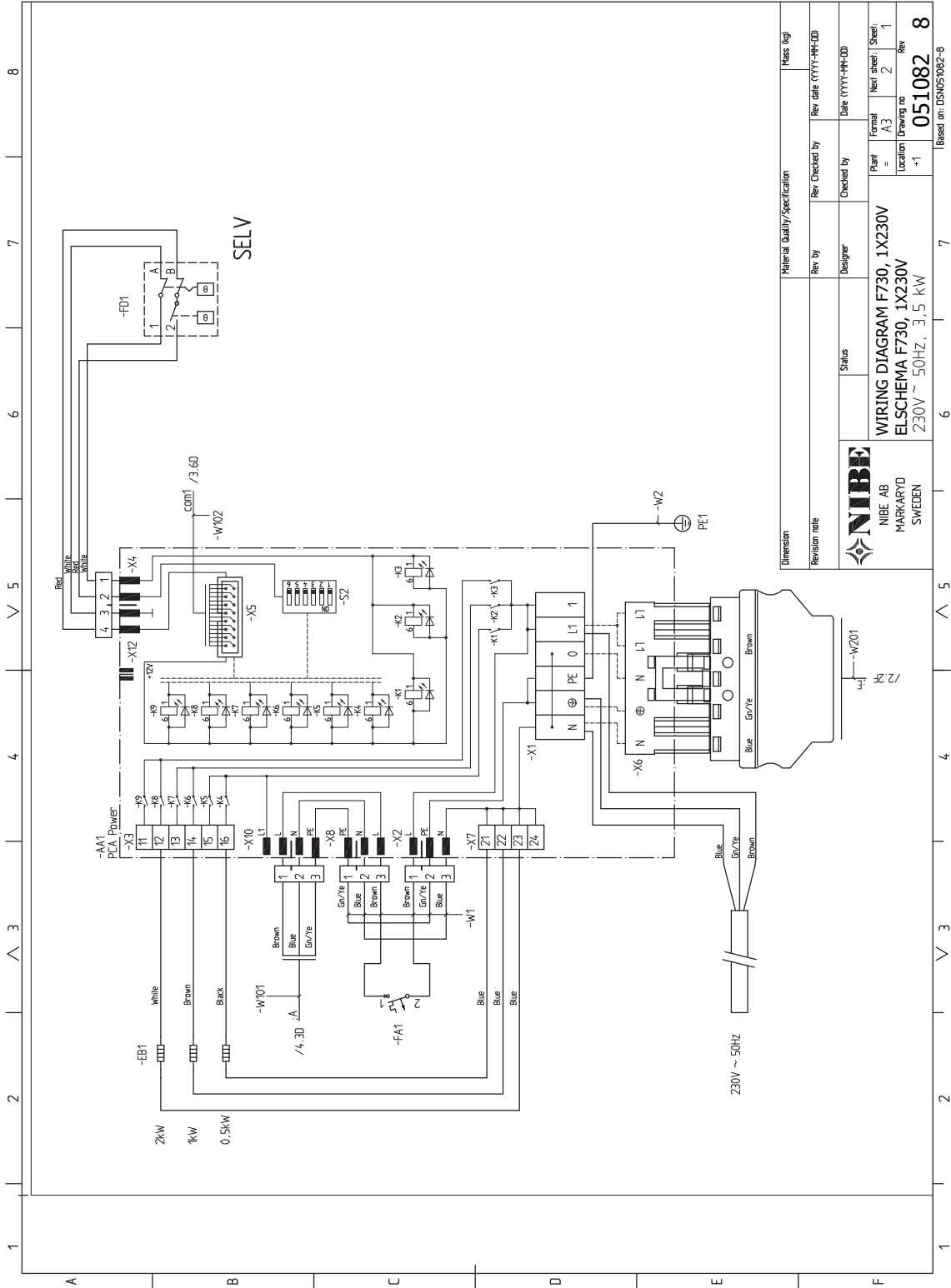

Material Quality/Specification		Mass (kg)	
Revision note	Rev. by	Rev. Checked by	Rev. date (YYYY-MM-DD)
Status	Designer	Checked by	Date (YYYY-MM-DD)
NIBE NIBE AB MARKARYD SWEDEN		Plant	Sheet
WIRING DIAGRAM F730, 1X230V ELSHEMA F730, 1X230V 230V ~ 50Hz, 3,5 kW		Location	Rev
		+1	051082
		8	
Based on: DSN051082-9			

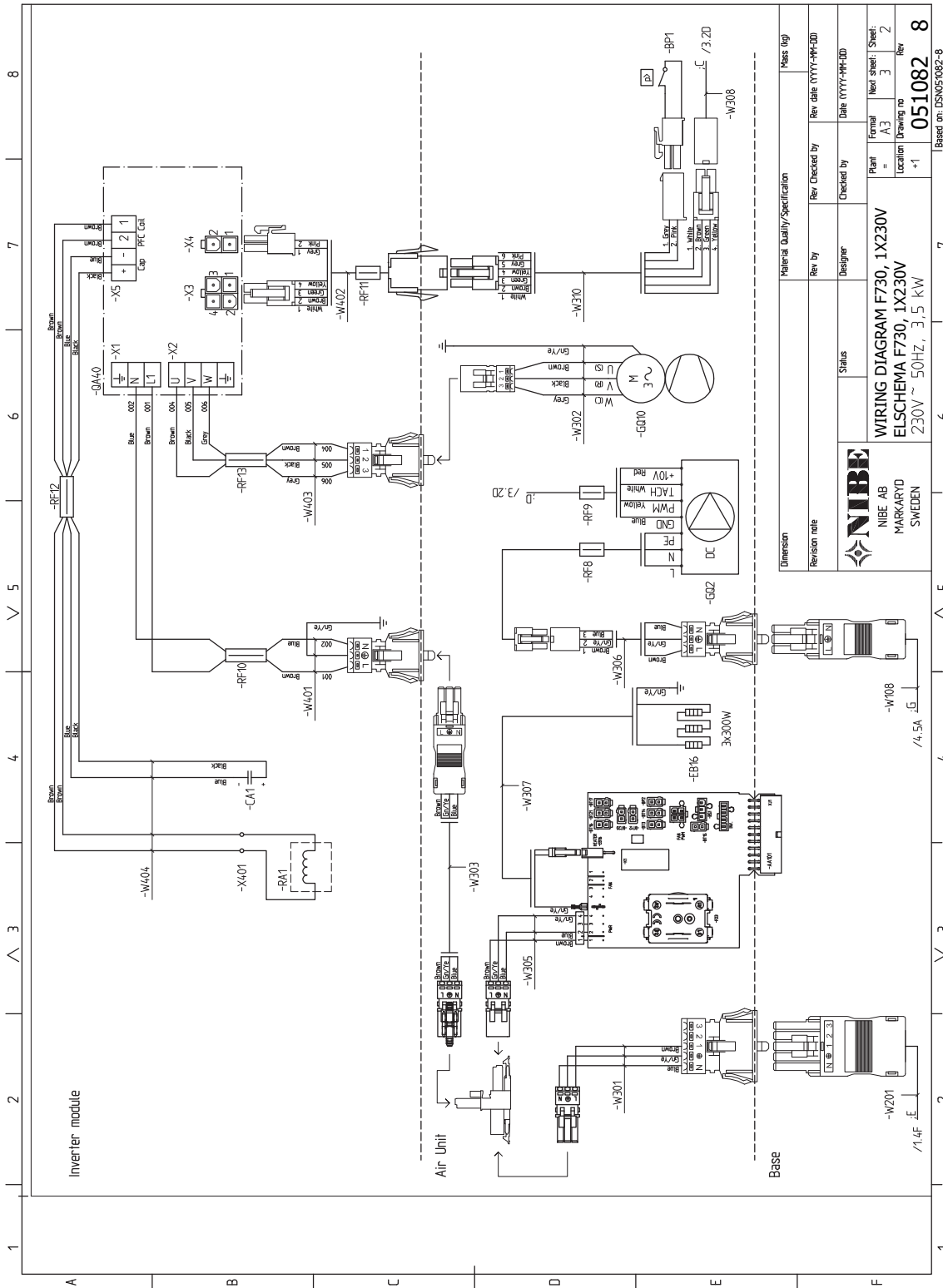

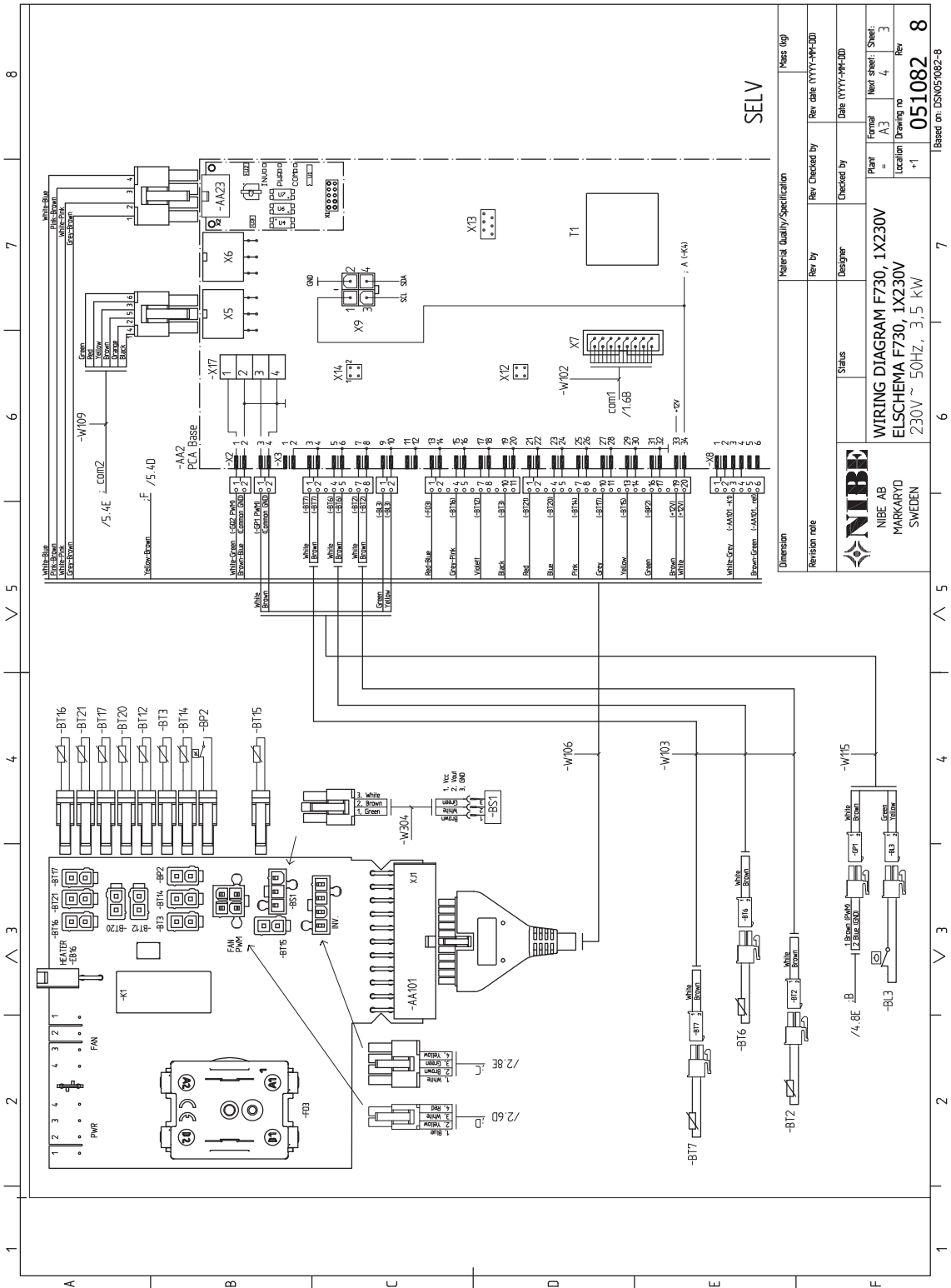

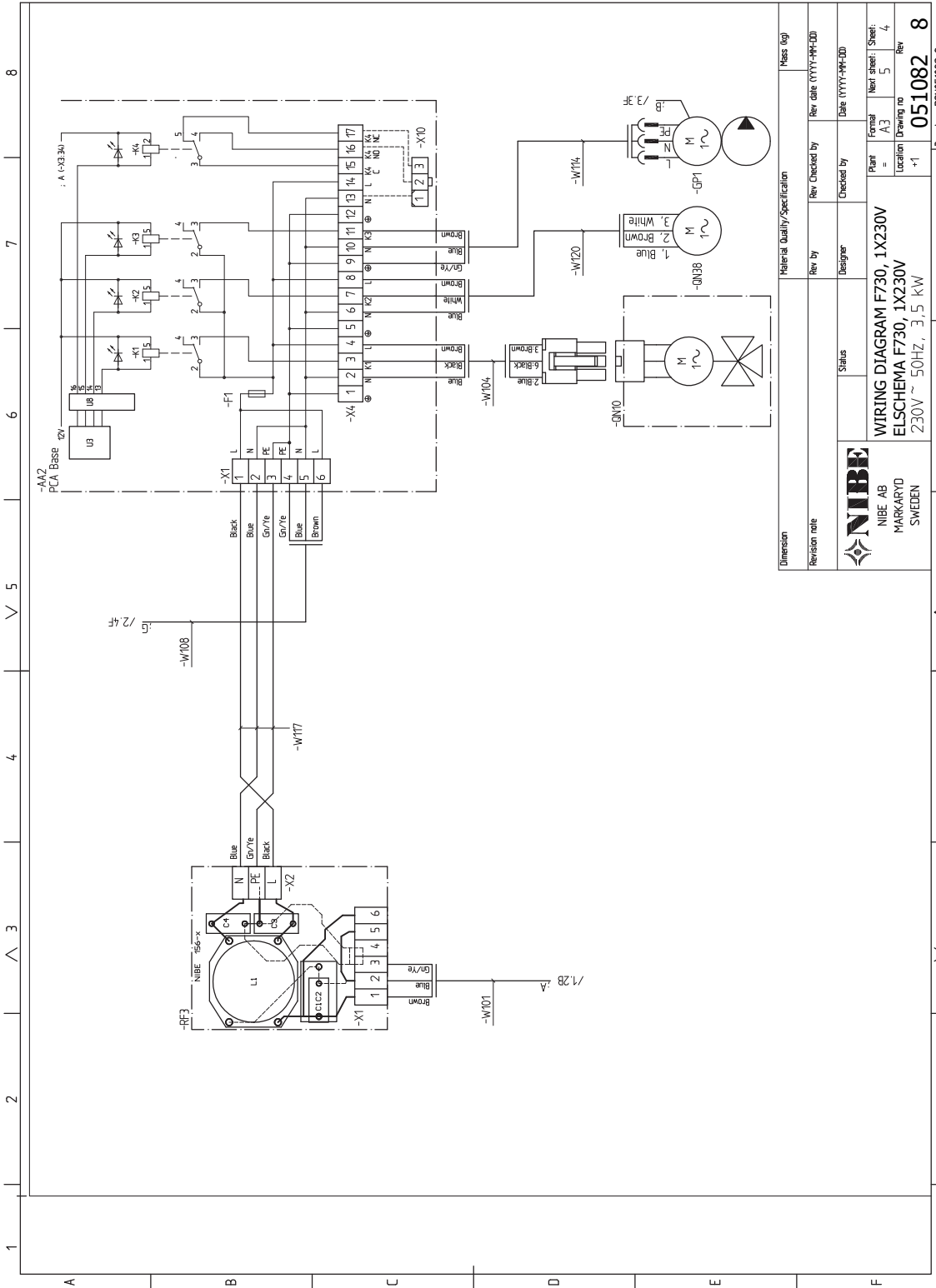

Material Quality/Specification		Mass (kg)	
Revision note	Rev by	Rev Checked by	Rev date (YYYY-MM-DD)
Status	Designer	Checked by	Date (YYYY-MM-DD)
NIBE NIBE AB MARKARYD SWEDEN		Plant	Formal
WIRING DIAGRAM F730, 1X230V ELSCHEMA F730, 1X230V 230V ~ 50Hz, 3,5 kW		Location	Sheet
		+1	5
			4
			Rev
			051082
			8
		Based on: DSN051082-8	

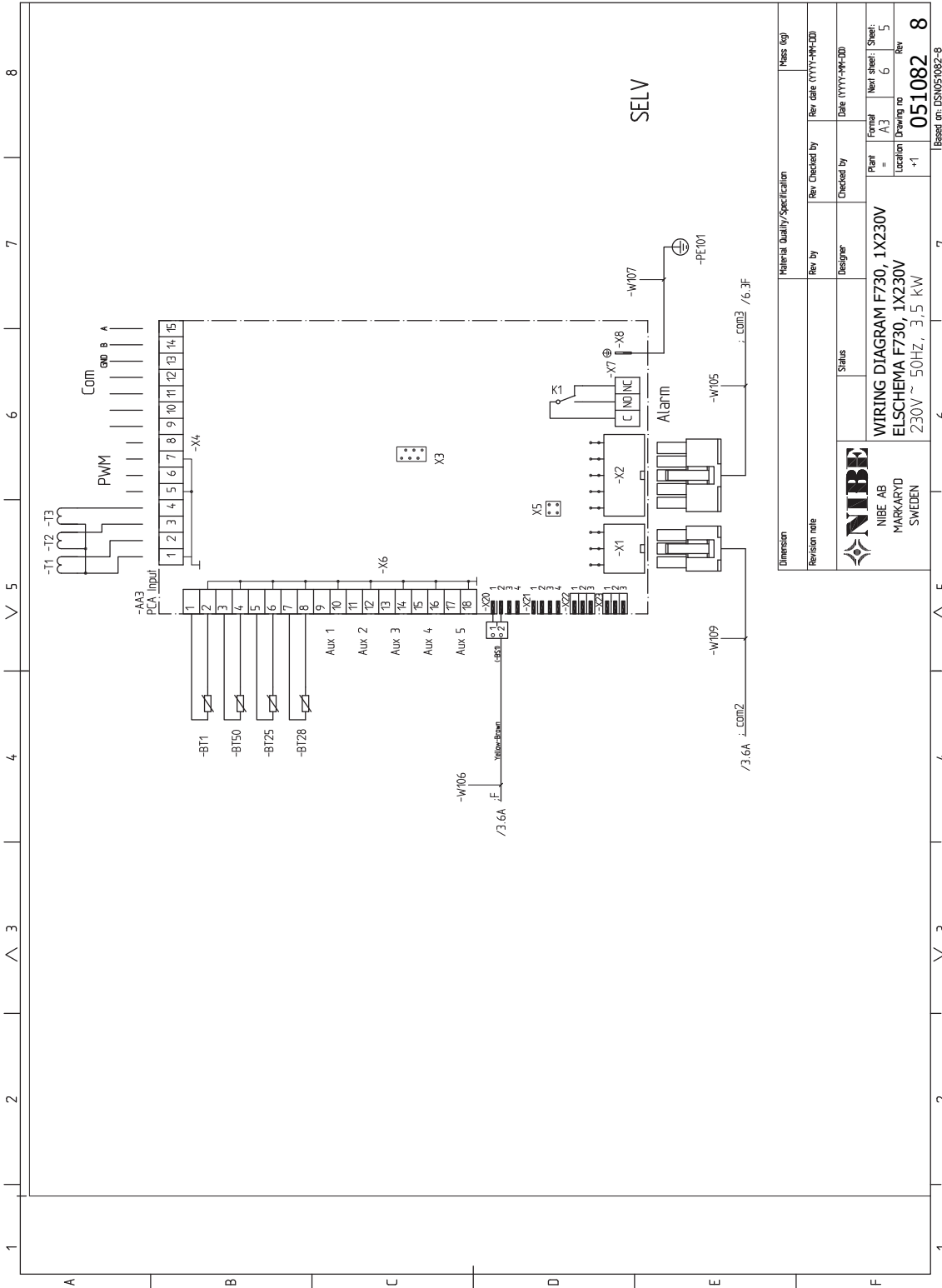

Material Quality/Specification		Mass (kg)	
Revision note	Rev. by	Rev. checked by	Rev. date (YYYY-MM-DD)
Status	Designer	Checked by	Date (YYYY-MM-DD)
		Plant =	Formal
NIBE AB MARKARYD SWEDEN		A3	A3
WIRING DIAGRAM F730, 1X230V ELSCHEMA F730, 1X230V 230V ~ 50Hz, 3,5 kW		Location	Sheet
		+1	6
		Drawing no	Rev
		051082	8
Based on: DSN051082-8			

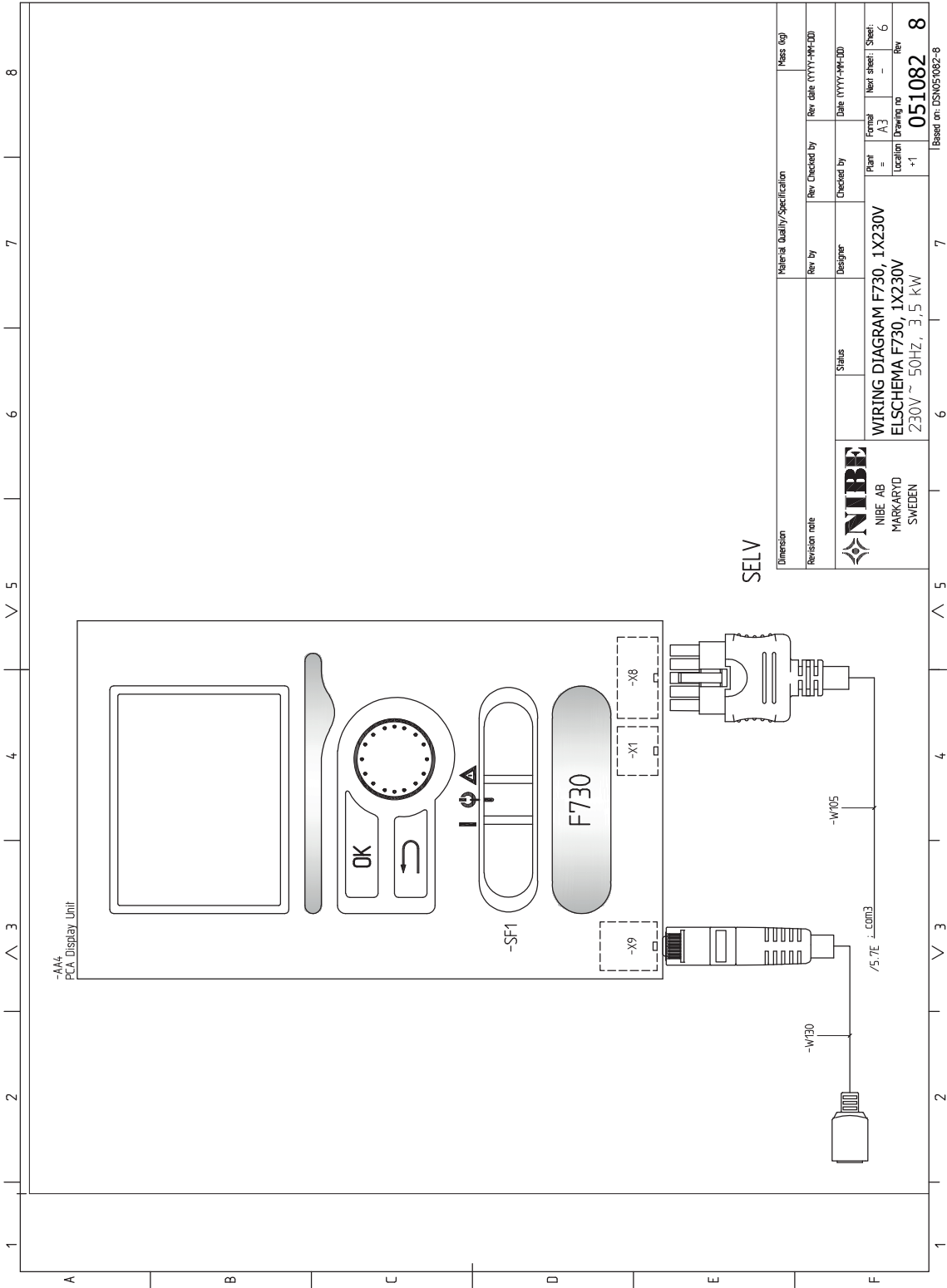

SELV

Dimension	Material Quality/Specification		Mass (kg)
Revision note	Rev. by	Rev. Checked by	Rev. date (YYYY-MM-DD)
 NIBE AB MARKARYD SWEDEN	Status	Designer	Date (YYYY-MM-DD)
	WIRING DIAGRAM F730, 1X230V ELSCHEMA F730, 1X230V 230V ~ 50Hz, 3,5 kW		Plant = A3 Location +1 Drawing no. 051082 Rev. 8
Based on: DSN051082-8			

13 Item register

Item register

A

Accessibility, electrical connection, 25
Accessories, 56
Alarm, 54
Assembly, 8

B

Back button, 38

C

Cable lock, 25
Cleaning the water heater, 51
Cold and hot water, 17
Commissioning and adjusting, 33
 Filling and venting, 33
 Preparations, 33
 Start guide, 34
 Start-up and inspection, 34
Connecting accessories, 32
Connecting cold and hot water, 17
Connecting the climate system, 17
Connections, 26
Control, 38, 42
 Control - Introduction, 38
 Control - Menus, 42
Control - Introduction, 38
 Display unit, 38
 Menu system, 39
Control knob, 38
Control - Menus, 42
 Menu 5 - SERVICE, 44
Country specific information, 5

D

Delivery and handling, 8
 Assembly, 8
 Installation area, 8
 Removing parts of the insulation, 10
 Removing the covers, 10
 Supplied components, 9
 Transport, 8
Dimensions and pipe connections, 16
Dimensions and setting-out coordinates, 57
Display, 38
Display unit, 38
 Back button, 38
 Control knob, 38
 Display, 38
 OK button, 38
 Status lamp, 38
 Switch, 38
Disturbances in comfort, 54
 Alarm, 54
 Manage alarm, 54
 Troubleshooting, 54
Draining the climate system, 51
Draining the hot water heater, 51

E

Electrical addition - maximum output, 28
Electrical circuit diagram, 63
Electrical connections, 24
 Accessibility, electrical connection, 25
 Cable lock, 25
 Connecting accessories, 32
 Connections, 26
 Electrical addition - maximum output, 28
 External connection options, 29
 General, 24

Load monitor, 29
Miniature circuit-breaker, 24
Optional connections, 29
Outdoor sensor, 26
Outdoor sensor for the outdoor air damper, 26
Power connection, 26
Removing the cover, base board, 25
Removing the cover, immersion heater circuit board, 25
Removing the hatch, input circuit board, 25
Room sensor, 27
Settings, 28
Standby mode, 28
Temperature limiter, 24
Uplink, 29
Energy labelling, 61
 Data for energy efficiency of the package, 61
 Information sheet, 61
 Technical documentation, 62
Exhaust air duct, 23
External connection options, 29
 Possible selection for AUX inputs, 29
 Possible selections for AUX output, 31

F

Filling and venting, 33
 Filling the climate system, 33
 Filling the hot water heater, 33
 Venting the climate system, 33
Filling the climate system, 33
Filling the hot water heater, 33

H

Heating medium side, 17
Help menu, 34, 41

I

Important information, 4
 Country specific information, 5
 Recovery, 5
Inspection of the installation, 7
Installation alternative, 18
 Connecting hot water circulation, 22
 Extra hot water heaters, 22
 Two or more climate systems, 22
 Water heater with immersion heater, 22
 Water heater without immersion heater, 22
Installation area, 8

M

Manage alarm, 54
Marking, 4
Menu 5 - SERVICE, 44
Menu system, 39
 Help menu, 34, 41
 Operation, 40
 Scroll through the windows, 41
 Selecting menu, 40
 Selecting options, 40
 Setting a value, 40
 Use the virtual keyboard, 41
Miniature circuit-breaker, 24

O

OK button, 38
Operation, 40
Optional connections, 29
Outdoor sensor, 26
Outdoor sensor for the outdoor air damper, 26

P

- Pipe and ventilation connections, 14
 - Cold and hot water, 17
 - Connecting cold and hot water, 17
 - Connecting the climate system, 17
 - Dimensions and pipe connections, 16
 - Exhaust air duct, 23
 - General pipe connections, 14
 - Heating medium side, 17
 - Installation alternative, 18
 - Maximum boiler and radiator volumes, 15
 - Pipe dimensions, 16
 - Setting out dimensions, 16
 - Symbol key, 17
- Pipe dimensions, 16
- Possible selection for AUX inputs, 29
- Possible selections for AUX output, 31
- Power connection, 26
- Preparations, 33

R

- Remove parts of the insulation, 10
- Removing the cover, base board, 25
- Removing the cover, immersion heater circuit board, 25
- Removing the covers, 10
- Removing the hatch, input circuit board, 25
- Room sensor, 27

S

- Safety information
 - Inspection of the installation, 7
 - Marking, 4
 - Serial number, 5
 - Symbols, 4
 - Symbols on F730, 4
 - Warranty information, 5
 - Scroll through the windows, 41
 - Selecting menu, 40
 - Selecting options, 40
 - Serial number, 5
 - Service, 50
 - Service actions, 51
 - Service actions, 51
 - Cleaning the water heater, 51
 - Draining the climate system, 51
 - Draining the hot water heater, 51
 - Standby mode, 51
 - Temperature sensor data, 51
 - USB service outlet, 52
 - Setting a value, 40
 - Setting out dimensions, 16
 - Settings, 28
 - Standby mode, 51
 - Power in emergency mode, 28
 - Start guide, 34
 - Start-up and inspection, 34–35
 - Setting the pump speed, 35
 - Setting the ventilation, 35
 - Status lamp, 38
 - Supplied components, 9
 - Switch, 38
 - Symbol key, 17
 - Symbols, 4
 - Symbols on F730, 4
- ## **T**
- Technical data, 57
 - Dimensions and setting-out coordinates, 57
 - Electrical circuit diagram, 63
 - Technical Data, 59
 - Technical Data, 59

- Temperature limiter, 24
 - Resetting, 24
- Temperature sensor data, 51
- The heat pump design, 12
 - Component locations, 12
 - List of components, 13
- Transport, 8
- Troubleshooting, 54

U

- Uplink, 29
- USB service outlet, 52
- Use the virtual keyboard, 41

V

- Venting the climate system, 33

W

- Warranty information, 5

Service Record

It is recommended that your heating system is serviced regularly and that the appropriate Service Interval Record is completed.

Service Provider

Before completing the appropriate Service Interval Record below, please ensure you have carried out the service as described in the manufacturer's instructions.

Always use the manufacturer's specified spare part when replacing controls.

Service 1

Date: _____

Engineer Name: _____

Company Name: _____

Telephone No. _____

Operative ID No. _____

Comments: _____

Signature: _____

Service 2

Date: _____

Engineer Name: _____

Company Name: _____

Telephone No. _____

Operative ID No. _____

Comments: _____

Signature: _____

Service 3

Date: _____

Engineer Name: _____

Company Name: _____

Telephone No. _____

Operative ID No. _____

Comments: _____

Signature: _____

Service 4

Date: _____

Engineer Name: _____

Company Name: _____

Telephone No. _____

Operative ID No. _____

Comments: _____

Signature: _____

Service 5

Date: _____

Engineer Name: _____

Company Name: _____

Telephone No. _____

Operative ID No. _____

Comments: _____

Signature: _____

Service 6

Date: _____

Engineer Name: _____

Company Name: _____

Telephone No. _____

Operative ID No. _____

Comments: _____

Signature: _____

Service 7

Date: _____

Engineer Name: _____

Company Name: _____

Telephone No. _____

Operative ID No. _____

Comments: _____

Signature: _____

Service 8

Date: _____

Engineer Name: _____

Company Name: _____

Telephone No. _____

Operative ID No. _____

Comments: _____

Signature: _____

Service 9

Date: _____

Engineer Name: _____

Company Name: _____

Telephone No. _____

Operative ID No. _____

Comments: _____

Signature: _____

Service 10

Date: _____

Engineer Name: _____

Company Name: _____

Telephone No. _____

Operative ID No. _____

Comments: _____

Signature: _____

NIBE Energy Systems Ltd
3C Broom Business Park
Bridge Way
Chesterfield S41 9QG
Phone 0845 095 1200
Fax 0845 095 1201
info@nibe.co.uk
www.nibe.co.uk



431702