



User manual
NIBE™ F135
Exhaust air module

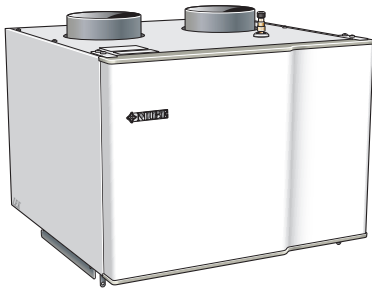

Table of Contents

1	<i>Important information</i>	2
	Installation data	2
	Safety information	3
	Serial number	4
	Contact information	5
	F135 – An excellent choice	7
2	<i>The heating installation – the heart of the house</i>	8
	The function of the exhaust air module	9
	Maintenance of F135	10
3	<i>Disturbances in comfort</i>	12
	Info menu indoor module	12
	Manage alarm (NIBE Indoor module)	12
	Troubleshooting	13
4	<i>Technical data</i>	15
5	<i>Glossary</i>	16
	<i>Index</i>	18

1 Important information

Installation data

Product	F135
Serial number	
Installation date	
Installer	

No.	Name	Factory settings	Set	✓	Accessories
5.1.5	Fan (fan speed, normal mode) Exhaust air fan installation	70%			
5.3.14	Pump speed	70%			

Serial number must always be given

Certification that the installation is carried out according to instructions in NIBE's installer manual and applicable regulations.

Date _____ Signed _____

Safety information

This appliance can be used by children aged from 8 years and above and persons with reduced physical, sensory or mental capabilities or lack of experience and knowledge if they have been given supervision or instruction concerning use of the appliance in a safe way and understand the hazards involved. Children shall not play with the appliance. Cleaning and user maintenance shall not be made by children without supervision.

Rights to make any design or technical modifications are reserved.

©NIBE 2015.

Symbols



NOTE

This symbol indicates danger to machine or person.



Caution

This symbol indicates important information about what you should observe when maintaining your installation.



TIP

This symbol indicates tips on how to facilitate using the product.

Marking

F135 is CE marked and fulfils IP21.

The CE marking means that NIBE ensures that the product meets all regulations that are placed on it based on relevant EU directives. The CE mark is obligatory for most products sold in the EU, regardless where they are made.

IP21 means that objects with a diameter larger than or equivalent to 12.5 mm cannot penetrate and cause damage and that the product is protected against vertically falling drops of water.

Serial number

The serial number can be found to the left, on top of F135.

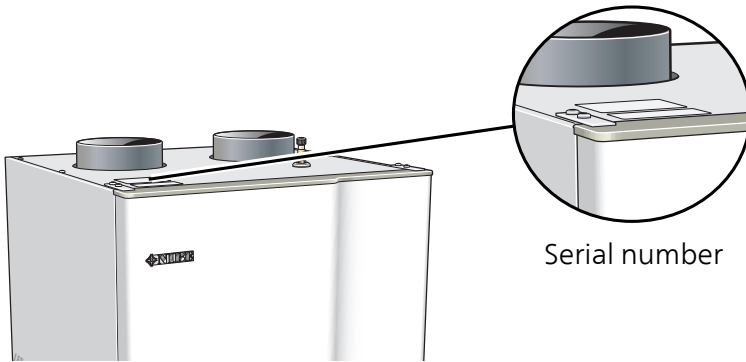

Caution

Always give the product's serial number (14 digits) when contacting your installer.

Contact information

- AT KNV Energietechnik GmbH**, Gahberggasse 11, 4861 Schörfling
Tel: +43 (0)7662 8963-0 Fax: +43 (0)7662 8963-44 E-mail: mail@knv.at
www.knv.at
- CH NIBE Wärmetechnik AG**, Winterthurerstrasse 710, CH-8247 Flurlingen
Tel: (52) 647 00 30 Fax: (52) 647 00 31 E-mail: info@nibe.ch
www.nibe.ch
- CZ Druzstevni zavody Drazice s.r.o.**, Drazice 69, CZ - 294 71 Benatky nad Jizerou
Tel: +420 326 373 801 Fax: +420 326 373 803 E-mail: nibe@nibe.cz
www.nibe.cz
- DE NIBE Systemtechnik GmbH**, Am Reiherpfahl 3, 29223 Celle
Tel: 05141/7546-0 Fax: 05141/7546-99 E-mail: info@nibe.de
www.nibe.de
- DK Vølund Varmeteknik A/S**, Member of the Nibe Group, Brogårdsvej 7, 6920 Videbæk
Tel: 97 17 20 33 Fax: 97 17 29 33 E-mail: info@volundvt.dk
www.volundvt.dk
- FI NIBE Energy Systems OY**, Juurakkotie 3, 01510 Vantaa
Puh: 09-274 697 0 Fax: 09-274 697 40 E-mail: info@nibe.fi www.nibe.fi
- FR NIBE Energy Systems France Sarl**, Zone industrielle RD 28, Rue du Pou du Ciel, 01600 Reyrieux
Tel : 04 74 00 92 92 Fax : 04 74 00 42 00 E-mail: info@nibe.fr
www.nibe.fr
- GB NIBE Energy Systems Ltd**, 3C Broom Business Park, Bridge Way, Chesterfield S41 9QG
Tel: 0845 095 1200 Fax: 0845 095 1201 E-mail: info@nibe.co.uk
www.nibe.co.uk
- NL NIBE Energietechniek B.V.**, Postbus 634, NL 4900 AP Oosterhout
Tel: 0168 477722 Fax: 0168 476998 E-mail: info@nibenl.nl
www.nibenl.nl
- NO ABK AS**, Brobekkveien 80, 0582 Oslo, Postadresse: Postboks 64 Vollebakk, 0516 Oslo
Tel. sentralbord: +47 23 17 05 20 E-mail: post@abkklima.no www.nibeenergysystems.no

- PL NIBE-BIAWAR Sp. z o. o.** Aleja Jana Pawła II 57, 15-703 BIAŁYSTOK
Tel: 085 662 84 90 Fax: 085 662 84 14 E-mail: sekretariat@biawar.com.pl
www.biawar.com.pl
- RU © "EVAN"** 17, per. Boynovskiy, Nizhny Novgorod
Tel./fax +7 831 419 57 06 E-mail: info@evan.ru www.nibe-evan.ru
- SE NIBE AB Sweden**, Box 14, Hannabadsvägen 5, SE-285 21 Markaryd
Tel: +46-(0)433-73 000 Fax: +46-(0)433-73 190 E-mail: info@nibe.se
www.nibe.se

For countries not mention in this list, please contact Nibe Sweden or check www.nibe.eu for more information.

F135 – An excellent choice

F135 is part of a new generation of exhaust air modules, which have been introduced to supply your home with inexpensive and environmentally friendly heating. F135 is connected between the indoor module and air-water heat pump and combines recycling of mechanical exhaust air by exploiting the heat in the ventilation air to heat the house and hot water at the same time that the house is ventilated. All control of F135 is from the indoor module.

Excellent properties for F135:

- ***DC fan***

An energy efficient DC fan (Class A) is integrated in the exhaust air module.

- ***Low noise level***

The exhaust air module has a very low noise level.

- ***Easy to install***

The exhaust air module is easy to install together with the indoor module and air/water heat pump. During installation the exhaust air module is connected to the indoor module, which enables you to read off the exhaust air module's values from the indoor module's display.

2 The heating installation – the heart of the house

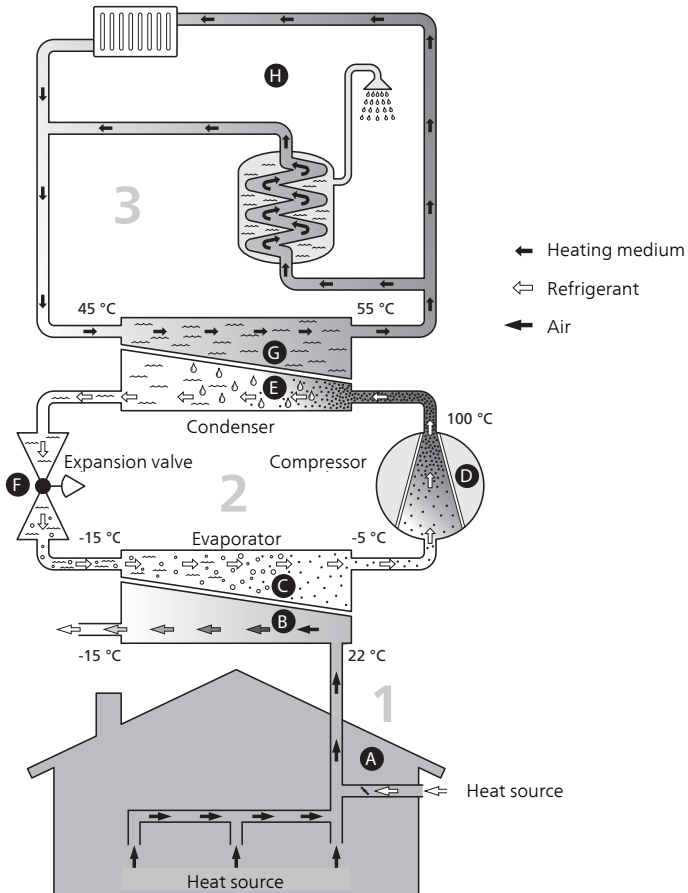

The temperatures are only examples and may vary between different installations and time of year.

The function of the exhaust air module

An exhaust air module uses the heat that is in the building's ventilation air to heat up the house. The conversion of the ventilation air's energy to residential heating is done in three different circuits. From the outgoing ventilation air (1), free heating energy is retrieved from the house and transported to the exhaust air module. The exhaust air module increases the retrieved heat's low temperature to a high temperature in the refrigerant circuit, (2). The heat is distributed around the building in the heating medium circuit (3).

Ventilation air

- A** The hot air is transferred from the rooms to the air-water pump via the house ventilation system.
- B** The fan then routes the air to the exhaust air module's evaporator. Here, the air releases the thermal energy to the brine and the air's temperature drops significantly. The cold air is then blown out of the house.

Refrigerant circuit

- C** A liquid, a refrigerant, circulates in a closed system in the exhaust air module, which also passes the evaporator. The refrigerant has a very low boiling point. In the evaporator the refrigerant receives the heat energy from the ventilation air and starts to boil.
- D** The gas that is produced during boiling is routed into an electrically powered compressor. When the gas is compressed, the pressure increases and the gas's temperature increases considerably, from approx. 5 °C to approx. 80°C.
- E** From the compressor, gas is forced into a heat exchanger, condenser, where it releases heat energy to the heating system in the house, whereupon the gas is cooled and condenses to a liquid form again.
- F** As the pressure is still high, the refrigerant can pass an expansion valve, where the pressure drops so that the refrigerant returns to its original temperature. The refrigerant has now completed a full cycle. It is routed to the evaporator again and the process is repeated.

Heat medium circuit

- G** The heat energy that the refrigerant produces in the condenser is retrieved by the climate system's water, heating medium, which is heated to 55 °C (supply temperature).

Ventilation

- J** The hot air is transferred from the rooms to the heat pump via the exhaust air module.
- K** The fan then routes the air to the exhaust air module heat exchanger. Here, the air releases the heating energy to the brine and the air's temperature drops significantly. The cold air is then blown out of the house.

Maintenance of F135

Regular checks

Your exhaust air module requires minimal maintenance after commissioning. On the other hand, it is recommended that you check your installation regularly.

If F135 is installed with an indoor module and something untoward occurs, a message appears regarding the malfunction in the form of different alarm texts in the indoor module display.

Cleaning the ventilation devices

The building's ventilation devices should be cleaned regularly with, for example, a small brush to maintain the correct ventilation.

The device settings must not be changed.

NOTE

If you take down more than one ventilation device for cleaning, do not mix them up.

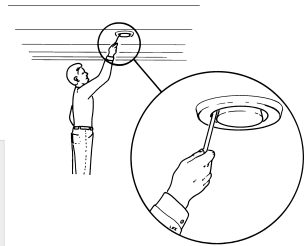

The temperatures are only examples and may vary between different installations and time of year.

Cleaning the air filter

Clean the F135's air filter regularly, how often depends on the amount of dust in the ventilation air. Select what is most suitable for your installation.

1. Cut the power to the exhaust air module.
2. Pull out the filter cassette.
3. Take out the filter and shake/vacuum off any dirt. Do not use water or other liquids for cleaning.
4. Check that the filter is not damaged.
5. Carry out assembly in reverse order.

Even if the filter appears clean, dirt collects in it and this affects the efficiency of the filter. Therefore, replace it after 2 years. New filters can be ordered via the installer.

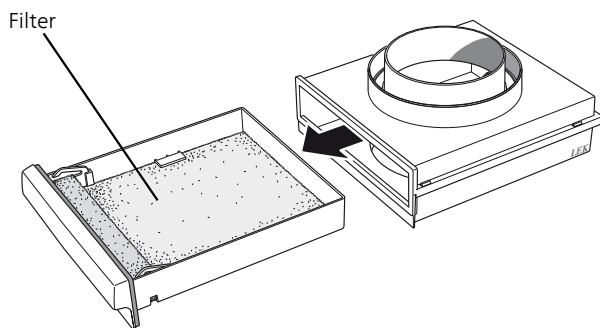

Caution

The exhaust air module starts when the supply cable is connected to an earthed socket.

Settings

All settings for F135, such as fan speed and scheduling, are carried out in the indoor module. See the indoor module manual for more information.

3 Disturbances in comfort

In most cases, the indoor module notes a malfunction (malfunctions can lead to disruption in hot water comfort) and indicates this with alarms in the display.

Info menu indoor module

All the indoor module measured values are gathered under menu 3.1 in the indoor module menu system. Looking through the values in this menu can often simplify finding the source of the fault.

Manage alarm (NIBE Indoor module)

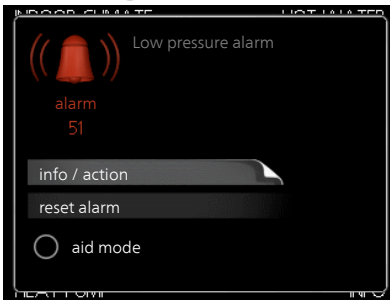

In the event of an alarm, some kind of malfunction has occurred, which is indicated by the status lamp changing from green continuously to red continuously. In addition, an alarm bell appears in the information window.

Alarm

If the alarm recurs, contact your installer for suitable remedial action.

NOTE

Always give the heat pump, control module and any accumulator tank serial numbers when contacting your installer.

In the event of an alarm with a red status lamp a malfunction has occurred that the indoor module cannot remedy itself. In the display, by turning the control knob and pressing the OK button, you can see the type of alarm it is and reset it. You can also choose to set the indoor module to aid mode.

info / action Here you can read what the alarm means and receive tips on what you can do to correct the problem that caused the alarm.

reset alarm In most cases it is enough to select "reset alarm" to correct the problem that caused the alarm. If a green light illuminates after selecting "reset alarm" the alarm has been remedied. If a red light is still visible and a menu called "alarm" is visible in the display, the problem that caused the alarm remains. If the alarm disappears and then returns, contact your installer.

aid mode "aid mode" is a type of emergency mode. This means that the indoor module produces heat and/or hot water, even though there is some kind of problem with the indoor module.

Problems with F135 do not affect the indoor module's operation. You do not need to select "aid mode" in event of problems with F135.



NOTE

To select aid mode an alarm action must be selected in the menu 5.1.4.



Caution

Selecting "aid mode" is not the same as correcting the problem that caused the alarm. The status lamp will therefore continue to be red.

Resetting the alarm

Alarm reset can be carried out in two ways.

1. Select "yes" in menu 4.8.
2. Restart of F135 (on/off of voltage to F135).

In the event of an alarm reset, the control system restarts in the heat pump and any alarms in F135 are reset.



NOTE

Contact your installer if the alarm recurs.

Troubleshooting

If the malfunction is not shown in the indoor module display, the following tips can be used:

Low or a lack of ventilation

- The ventilation is not adjusted.
 - Order ventilation adjustment.
- Filter blocked.
 - Clean or replace filter (see page 11).
- Exhaust air device blocked or throttled down too much.
 - Check and clean the exhaust air devices (see page 10).
- Fan speed in reduced mode.

- Enter menu 1.2 och välj "normal".
- External switch for changing the fan speed activated.
 - Check any external switches.

High or distracting ventilation

- The ventilation is not adjusted.
 - Order ventilation adjustment.
- Fan speed in forced mode.
 - Enter menu 1.2 and select "normal".
- External switch for changing the fan speed activated.
 - Check any external switches.
- Filter blocked.
 - Clean or replace filter (see page 11).

Gurgling sound

- Not enough water in the water seal.
 - Refill the water seal with water.
- Choked water seal.
 - Check and adjust the condensation water hose.

4 Technical data

Detailed technical specifications for this product can be found in the installation manual (www.nibe.eu).

5 Glossary

Climate system

The climate system can also be called the heating and/or cooling system. The building is cooled or heated using radiators, under floor coils or convector fans.

Compressor

Compresses the gas state refrigerant. When the refrigerant is compressed, the pressure and the temperature increase.

Condenser

Heat exchanger where the hot gas state refrigerant condenses (cooled and becomes a liquid) and releases heat energy to the house heating and hot water systems.

Disturbances in comfort

Disturbances in comfort are undesirable changes to the hot water/indoor comfort, for example when the temperature of the hot water is too low or if the indoor temperature is not at the desired level.

A malfunction in the heat pump can sometimes be noticed in the form of a disturbance in comfort.

In most cases, the heat pump notes operational interference and indicates this with alarms and shows instructions in the display.

Domestic hot water

The water one showers in for example.

Emergency mode

A mode that can be selected using the switch in the event of a fault, which means that the compressor stops. When the heat pump is in emergency mode, the building and/or hot water is heated using an immersion heater.

Evaporator

Heat exchanger where the refrigerant evaporates by retrieving heat energy from the air which then cools.

Exhaust air

The air that comes from the exhaust air device in the various rooms of the accommodation, to F135.

Exhaust air devices

Vents, usually in the ceiling, in the kitchen/bathroom/clothes closet where the air is drawn in to be forwarded to F135.

Expansion valve

Valve that reduces the pressure of the refrigerant, whereupon the temperature of the refrigerant drops.

Flow pipe

The line in which the heated water is transported from the heat pump out to the house heating system (radiators/heating coils).

Heat exchanger

Device that transfers heat energy from one medium to another without mixing mediums. Examples of different heat exchangers are evaporators and condensers.

Heating medium

Hot liquid, usually normal water, which is sent from the heat pump to the house climate system and makes the accommodation warm. The heating medium also heats the hot water.

Radiator

Another word for heating element. They must be filled with water in order to be used with F135.

Refrigerant

Substance that circulates around a closed circuit in the heat pump and that, through pressure changes, evaporates and condenses. During evaporation, the refrigerant absorbs heating energy and when condensing gives off heating energy.

Supply temperature

The temperature of the heated water that the heat pump sends out to the heating system. The colder the outdoor temperature, the higher the supply line temperature becomes.

6 Item register

C

Contact information, 5

D

Disturbances in comfort

 Manage alarm, 12

 Troubleshooting, 13

F

F135 – An excellent choice, 7

G

Glossary, 16

H

Heat pump function, 9

I

Important information, 2

 Contact information, 5

 F135 – An excellent choice, 7

 Installation data, 2

 Serial number, 4

Installation data, 2

M

Maintenance of F135, 10

 Regular checks, 10

Manage alarm, 12

R

Regular checks, 10

S

Serial number, 4

T

Technical data, 15

The heating installation – the heart of the house, 8

Troubleshooting, 13

NIBE AB Sweden
Hannabadsvägen 5
Box 14
SE-285 21 Markaryd
info@nibe.se
www.nibe.eu

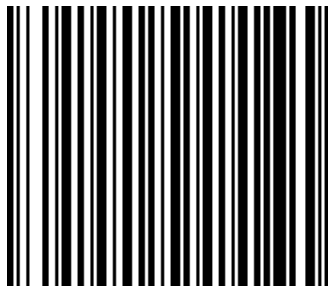

331433