

Ground Source Heat Pump NIBE™ AP-BW30

Heat pump for commercial projects

NEW



Features of NIBE™ AP-BW30

Ground source heat pump up to 160 kW (in single unit)

Heating and cooling with same unit

Heat recovery from waste heat

Cascade for very high heating output

- Combination up to 4pcs 29 - 69 kW
- Combination up to 4pcs 85-160 kW

Low sound pressure level down to 39 dB(A)

Single compressor unit (29-69 kW)

Double compressor unit (85-160 kW)

Insertion via standard doors possible

Small space requirement - small footprint

- L 1350 x W 912 X H 1030 inclusive frame (29-69 kW)
- L 1400 x W 913 x H 1847 inclusive frame (85 - 160 kW)

Frame is completely noise decoupled to the unit

High temperature versions available, up to 70°C (29-69kW)

Solid Construction

Easy to transport

NIBE AP-BW30

Efficiency and renewable heat

The supply of heat for residential, commercial and industrial properties accounts for a large percentage of their overall energy consumption. Improving energy efficiency is therefore one of the energy policy objectives. Increased energy efficiency and renewable heat mean more environmental relief and from an economic point of view, lower heating and running costs.

Heat pump can be easily integrated into a building management system. Utilisation of waste heat in industrial or commercial processes is also possible. A change from oil and gas to heat pump technology can often be used to achieve substantial savings - e.g. running costs and CO₂ emissions.



Heat pumps with high capacities!

Heat pumps

In apartment buildings, office and administration complexes, hotels and in industrial and commercial buildings, heat pumps are superior to conventional concepts, not only economically but also environmental.

Even more powerful

When installing up to four units in cascade, capacities up to 640 kW are possible with ground source heat pumps. Integrated systems controlled by a building management system can achieve an even higher heating capacity.

The units can be switched on and off as when necessary to enable economic operation

Active and passive cooling

If the installation is planned well, full air conditioning with chillers can be omitted with no loss of comfort and instead passive or active cooling is used.

Only heat pump systems offer the possibility for heating and active/passive cooling with one system using free environmental energy.

Flexibility with e.g. twin cascades

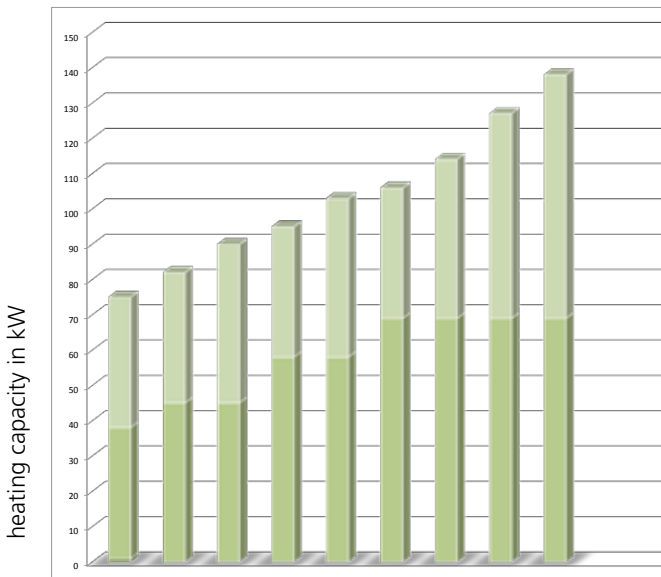

NIBE AP-BW30: -37 -45 -45 -58 -58 -54H -69 -69 -69
-37 -37 -45 -37 -45 -45 -45 -58 -69

First hand energy management!

BACnet/IP - perfect teamwork

The BACnet/IP virtual network enables NIBE heat pumps to be integrated into a building management system.

NIBE AP-CS 2.0

Controller device with LIN-Bus port.

Local Interconnect Network (LIN) is the specification for a serial communication system which was basically developed for communication of intelligent sensors and actors in the automobile industry.

- Intuitive operation via the jog dial
- Full graphic display with self-explanatory menu function
- USB connection (for reading out data or of software updates)
- Automatic screed heating program
- Start-Up Wizard
- Separate mode setting e.g automatic, party, holiday
- Weather compensated control of several heating circuits



Possible combination up to 4 pcs in cascade

NIBE AP-BW30-	29H	37	45	56H	58	69	85H	100	125	160
29H	x	x	x	x	x	x				
37	x	x	x	x	x	x				
45	x	x	x	x	x	x				
56H	x	x	x	x	x	x				
58	x	x	x	x	x	x				
69	x	x	x	x	x	x				
85H							x	x	x	x
100							x	x	x	x
125							x	x	x	x
160							x	x	x	x

Dimensions

NIBE AP-BW30-37 to NIBE AP-BW30-69

NIBE AP-BW30-39H and NIBE AP-BW30-56H

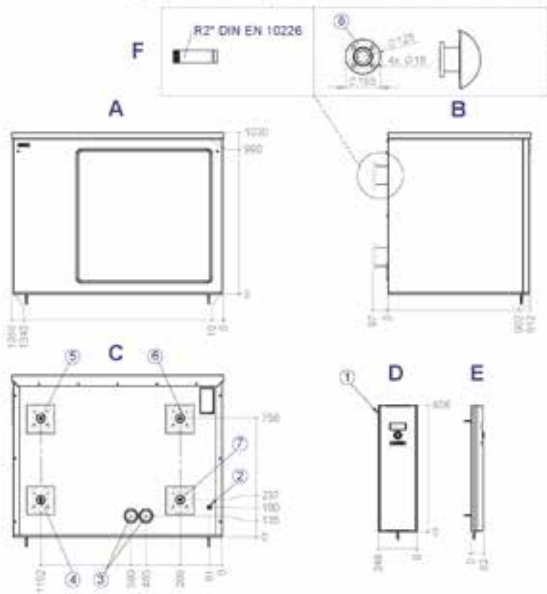

- A Front view
- B Side view from left
- C Rear view
- D Front view, control element
- E Side view from left, control element
- F Connection options

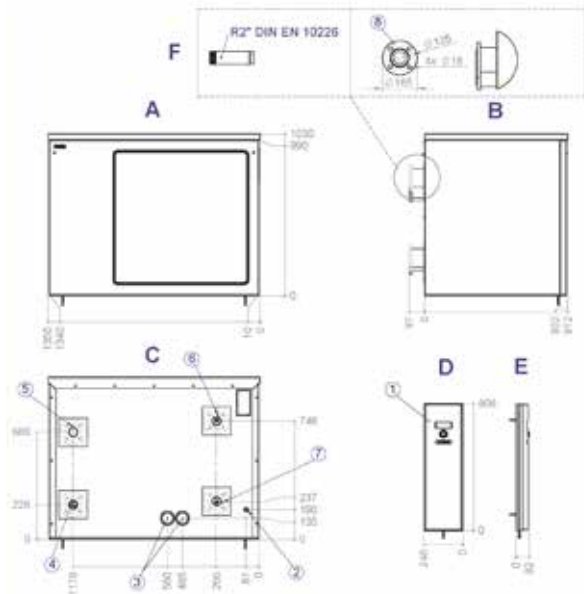

- 1 Control element (for wall-mounting)
- 2 Penetration for connection and LIN bus cable
- 3 Penetration for electric cable
- 4 Heat source outlet
- 5 Heat source inlet
- 6 Heating water outlet (flow)
- 7 Heating water inlet (return)
- 8 Flange DN50 PN10/16 DIN2566

NIBE AP-BW30 110, NIBE AP-BW30 125, NIBE AP-BW30 85H

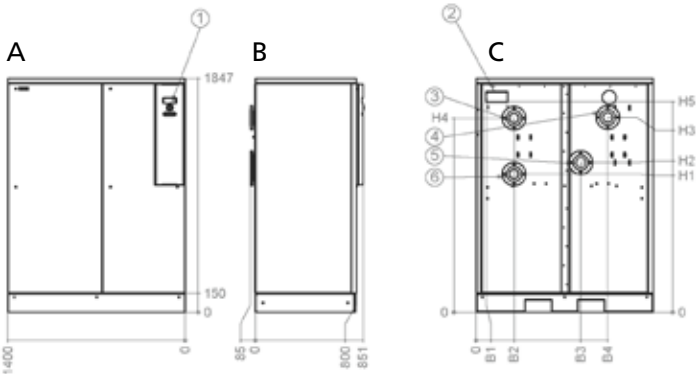

- A Front view
- B Side view from left
- C Rear view
- 1 Control Panel
- 2 Sleeves for electrical / sensor cables
- 3 Hot Water outlet (flow), flange DIN 2566
- 4 Heat source inlet, flange DIN 2566
- 5 Heat source outlet, flange DIN 2566
- 6 Hot water inlet (return), flange DIN 2566

Type	H1	H2	H3	H4	H5	B1	B2	B3	B4
BW30 110, 85H	1085	1182	1537	1541	1661	65	294	832	1043
BW30 125	1092	1182	1537	1533	1661	65	300	832	1043

NIBE AP-BW30 160

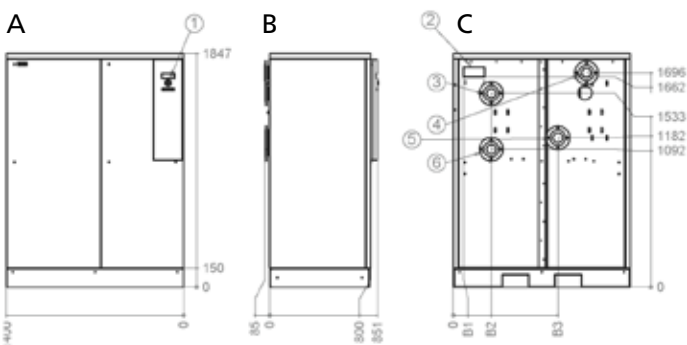

Type	B1	B2	B3	B4
BW30 110, 85H	65	294	832	1043
BW30 125	65	300	832	1043

Technical specifications

NIBE™ AP-BW30



NIBE™		AP-BW30-29H	AP-BW30-37	AP-BW30-45	AP-BW30-58	AP-BW30-69	AP-BW30-56H
Heating power/COP at B0/W35 ¹⁾	1 compressor	kW 27,5 / 4,30	37,2 / 4,80	45,0 / 4,80	57,6 / 4,80	68,5 / 4,60	53,8 / 4,50
Heating power/COP at B0/W45 ¹⁾	1 compressor	kW 26,7 / 3,40	35,8 / 3,70	42,7 / 3,70	55,8 / 3,80	66,1 / 3,60	52,9 / 3,80
Heating power/COP at B7/W35 ¹⁾	1 compressor	kW 33,2 / 5,10	45,4 / 5,60	55,0 / 5,70	71,1 / 5,80	84,1 / 5,40	65,9 / 5,20
Heating power/COP at B0/W50 ¹⁾	1 compressor	kW 25,9 / 2,70	34,8 / 2,90	41,1 / 2,90	54,1 / 3,00	64,6 / 2,90	52,1 / 3,10
Heat circuit	°C	20 - 64	20 - 57	20 - 58	20 - 60	20 - 60	20 - 64
Heat source	°C	-5 - 25					
Additional operating points		B4/W70	B3/W65	B0/W65		B0/W70	
Sound pressure level at 1m gap around the machine averaged (in free field)	dB (A)	43	39	41	42	44	
Sound power level as per EN12102	dB	58	54	56	57	59	
Connections heating circuit		DN50 DIN2566					
Connections brine circuit		DN50 DIN2566					
Refrigerant type / Filling capacity	- / kg	R134a/6,7	R410A/7,2	R410A/8,2	R410A/11,2	R410A/13,4	R134a/12,8
Voltage	- / A	3~/PE/400V/50Hz /					
All-pole circuit breaker for heat pump ²⁾		C40	C32	C40	C50		
Voltage controller/ circuit breaker ²⁾	- / A	1~/N/PE230V/50HZ / B16					
Weight	kg	319	371	385	441	484	521
L x W x H	mm	1350 x 912 x 1030 (inclusive frame)					

¹⁾ Standard point as per EN14511

²⁾ Observe local regulations

NIBE™		AP-BW30-85H	AP-BW30-110	AP-BW30-125	AP-BW30-160
Heating power/COP at B0/W35 ¹⁾	2 compressors	kW 88,0 / 4,1	107,5 / 4,3	125, / 4,3	161,1 / 4,4
Heating power/COP at B0/W35 ¹⁾	1 compressor	kW 46,5 / 4,2	57,0 / 4,4	66,3 / 4,4	85,6 / 4,5
Heating power/COP at B0/W50 ¹⁾	2 compressors	kW 86,4 / 3,0	107,6 / 3,1	125,2 / 3,1	161,8 / 3,2
Heating power/COP at B0/W50 ¹⁾	1 compressor	kW 42,5 / 3,2	57,1 / 3,2	66,4 / 3,2	85,8 / 3,3
Heating power/COP at B-5/W35 ¹⁾	2 compressors	78,0 / 3,8	96,5 / 3,9	112,3 / 3,9	145,1 / 4,0
Heating power/COP at B-5/W35 ¹⁾	1 compressor	kW 40,5 / 4,0	51,2 / 4,0	59,5 / 4,0	76,9 / 4,1
Heating power/COP at B-5/W50 ¹⁾	2 compressors	kW 76,0 / 3,0	95,2 / 2,8	110,8 / 2,8	143,2 / 2,9
Heating power/COP at B-5/W50 ¹⁾	1 compressor	kW 39,5 / 3,0	50,5 / 2,9	58,7 / 2,9	75,9 / 2,9
Heat circuit	°C	20 - 65	20 - 55		
Heat source	°C	-5 - 25			
Sound pressure level at 1m gap around the machine averaged (in free field)	dB (A)	64	62	64	66
Connections heating circuit		DN50 DIN2566		DN65 DIN2566	
Connections brine circuit		DN65 DIN2566			
Refrigerant type / Filling capacity	- / kg	R134a/17,0	R407C/19,0	R407C/18,8	R407C/20,7
Voltage	- / A	3~/PE/400V/50Hz			
All-pole circuit breaker for heat pump ²⁾		C80	C100	C125	C125
Voltage controller/ circuit breaker ²⁾	- / A	1~/N/PE230V/50HZ / B10			
Weight	kg	935	870	935	1000
L x W x H	mm	1400 x 913 x 1847			

¹⁾ Standard point as per EN 255

²⁾ Observe local regulations

