

Installer manual
NIBE™ F135
Exhaust air module

Table of Contents

1 Important information	4	Index	34
Safety information	4		
2 Delivery and handling	7		
Transport	7		
Assembly	7		
Supplied components	8		
Removing the covers	9		
3 The exhaust air module design	10		
4 Pipe and air connections	12		
General pipe connections	12		
Dimensions and pipe connections	13		
Mounting	14		
Connecting to indoor module and air-water heat pump	15		
Installation exhaust air	15		
General ventilation connections	18		
Exhaust air duct /kitchen fan	19		
Ventilation flow (exhaust air)	19		
Adjusting ventilation (exhaust air)	19		
5 Electrical connections	20		
General	20		
Connections	20		
Optional connections	21		
6 Commissioning and adjusting	22		
Preparations	22		
Filling and venting	22		
Start-up and inspection	23		
7 Disturbances in comfort	25		
Info menu indoor module	25		
Manage alarm (NIBE Indoor module)	25		
Troubleshooting	25		
8 Accessories	27		
Top cabinet	27		
9 Technical data	28		
Dimensions and setting-out coordinates	28		
Technical specifications	29		
Energy labelling	31		
Electrical circuit diagram	33		

1 Important information

Safety information

This manual describes installation and service procedures for implementation by specialists.

This appliance can be used by children aged from 8 years and above and persons with reduced physical, sensory or mental capabilities or lack of experience and knowledge if they have been given supervision or instruction concerning use of the appliance in a safe way and understand the hazards involved. Children shall not play with the appliance. Cleaning and user maintenance shall not be made by children without supervision.

Rights to make any design or technical modifications are reserved.

©NIBE 2016.

Symbols



NOTE

This symbol indicates danger to machine or person.



Caution

This symbol indicates important information about what you should observe when maintaining your installation.



TIP

This symbol indicates tips on how to facilitate using the product.

Marking

F135 is CE marked and fulfils IP21.

The CE marking means that NIBE ensures that the product meets all regulations that are placed on it based on relevant EU directives. The CE mark is obligatory for most products sold in the EU, regardless where they are made.

IP21 means that objects with a diameter larger than or equivalent to 12.5 mm cannot penetrate and cause damage and that the product is protected against vertically falling drops of water.

Serial number

The serial number can be found to the left, on top of F135.

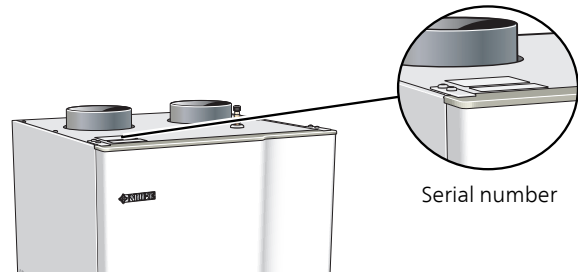

Caution

Always give the product's serial number (14 digits) when contacting your installer.

Recovery



Leave the disposal of the packaging to the installer who installed the product or to special waste stations.

Do not dispose of used products with normal household waste. It must be disposed of at a special waste station or dealer who provides this type of service.

Improper disposal of the product by the user results in administrative penalties in accordance with current legislation.

Country specific information

Installer manual

This installer manual must be left with the customer.

Inspection of the installation

Current regulations require the heating installation to be inspected before it is commissioned. The inspection must be carried out by a suitably qualified person.

✓	Description	Notes	Signature	Date
	Ventilation, exhaust air (page 15)			
	Setting the ventilation flow			
	Exhaust air filter			
	Heating medium (page 22)			
	System flushed			
	System vented			
	Circulation pump setting			
	Setting heating medium flow			
	Boiler pressure			
	Electricity (page 20)			
	Supply connected 230 V			
	Circuit fuses			

Contact information

- AT KNV Energietechnik GmbH**, Gahberggasse 11, 4861 Schörfling
Tel: +43 (0)7662 8963-0 Fax: +43 (0)7662 8963-44 E-mail: mail@knv.at www.knv.at
- CH NIBE Wärmetechnik c/o ait Schweiz AG**, Industriepark, CH-6246 Altishofen
Tel: (52) 647 00 30 Fax: (52) 647 00 31 E-mail: info@nibe.ch www.nibe.ch
- CZ Druzstevni zavody Drazice s.r.o.**, Drazice 69, CZ - 294 71 Benatky nad Jizerou
Tel: +420 326 373 801 Fax: +420 326 373 803 E-mail: nibe@nibe.cz www.nibe.cz
- DE NIBE Systemtechnik GmbH**, Am Reiherpfahl 3, 29223 Celle
Tel: 05141/7546-0 Fax: 05141/7546-99 E-mail: info@nibe.de www.nibe.de
- DK Vølund Varmeteknik A/S**, Member of the Nibe Group, Brogårdsvej 7, 6920 Videbæk
Tel: 97 17 20 33 Fax: 97 17 29 33 E-mail: info@volundvt.dk www.volundvt.dk
- FI NIBE Energy Systems OY**, Juurakkotie 3, 01510 Vantaa
Puh: 09-274 697 0 Fax: 09-274 697 40 E-mail: info@nibe.fi www.nibe.fi
- FR NIBE Energy Systems France Sarl**, Zone industrielle RD 28, Rue du Pou du Ciel, 01600 Reyrieux
Tel : 04 74 00 92 92 Fax : 04 74 00 42 00 E-mail: info@nibe.fr www.nibe.fr
- GB NIBE Energy Systems Ltd**, 3C Broom Business Park, Bridge Way, Chesterfield S41 9QG
Tel: 0845 095 1200 Fax: 0845 095 1201 E-mail: info@nibe.co.uk www.nibe.co.uk
- NL NIBE Energietechnik B.V.**, Postbus 634, NL 4900 AP Oosterhout
Tel: 0168 477722 Fax: 0168 476998 E-mail: info@nibenl.nl www.nibenl.nl
- NO ABK AS**, Brobekkveien 80, 0582 Oslo, Postadresse: Postboks 64 Vollebekk, 0516 Oslo
Tel. sentralbord: +47 23 17 05 20 E-mail: post@abkklima.no www.nibeenergysystems.no
- PL NIBE-BIAWAR Sp. z o. o.** Aleja Jana Pawła II 57, 15-703 BIAŁYSTOK
Tel: 085 662 84 90 Fax: 085 662 84 14 E-mail: sekretariat@biawar.com.pl www.biawar.com.pl
- RU © "EVAN"** 17, per. Boynovskiy, Nizhny Novgorod
Tel./fax +7 831 419 57 06 E-mail: info@evan.ru www.nibe-ivan.ru
- SE NIBE AB Sweden**, Box 14, Hannabadsvägen 5, SE-285 21 Markaryd
Tel: +46-(0)433-73 000 Fax: +46-(0)433-73 190 E-mail: info@nibe.se www.nibe.se

For countries not mention in this list, please contact Nibe Sweden or check www.nibe.eu for more information.

2 Delivery and handling

Transport

F135 should be transported and stored vertically in a dry place.

Assembly

- F135 is installed freestanding on brackets or a suitable flat surface. Noise from the circulation pump, fan and compressor can be transferred to the brackets or the surface that F135 is placed on. Use the product's adjustable feet to obtain a horizontal and stable set-up.

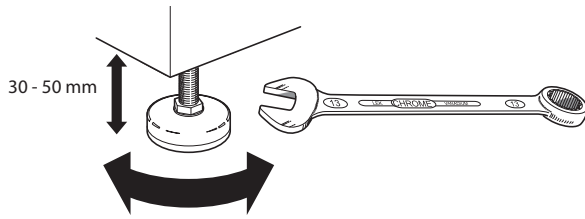

- F135 must be positioned with the back towards a wall. Install the brackets or position F135 against an outside wall, ideally in a room where noise does not matter, in order to eliminate noise problems. If this is not possible, avoid placing it against a wall behind a bedroom or other room where noise may be a problem.
- Wherever the unit is located, walls to sound sensitive rooms should be fitted with sound insulation.
- Route pipes so they are not fixed to an internal wall that backs on to a bedroom or living room.

Installation area

Leave a free space of 800 mm in front of the exhaust air module. Approx. 50 mm free space is required on each side in order to remove the side panels. The panels do not need to be removed during servicing, all servicing can be carried out from the front. Leave space between the exhaust air module and the wall behind (and any routing of supply cables and pipes) to reduce the risk of any vibration being propagated.

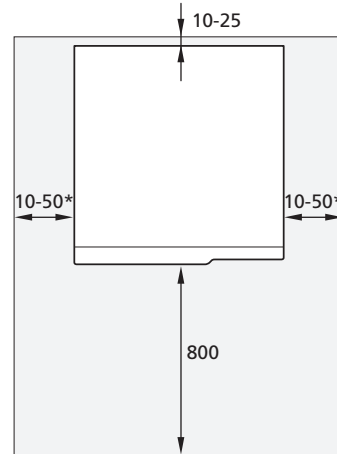

* Depending on whether the panels can be removed or not.



NOTE

Ensure that there is sufficient space (300 mm) above F135 for installing ventilation hoses.

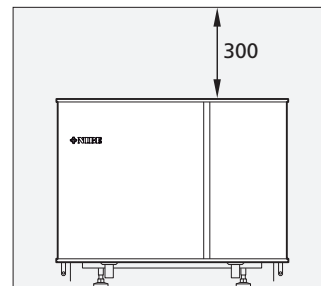

Supplied components

Location

The kit of supplied items is placed on top of the product.



Air connection



Silencer

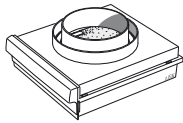

Filter cartridge

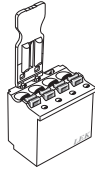

4-pin terminal block

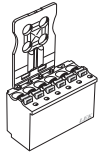

6-pin sensor connector

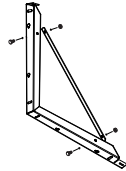

2 x bracket 6 x nuts
6 x screws 4 x washers

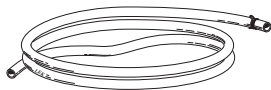

Drain hose Ø 20 mm
L=2200 mm



Circulation pump



Power supply cable



Communication cable



Choke washer Ø 22 mm

Removing the covers

Front hatch

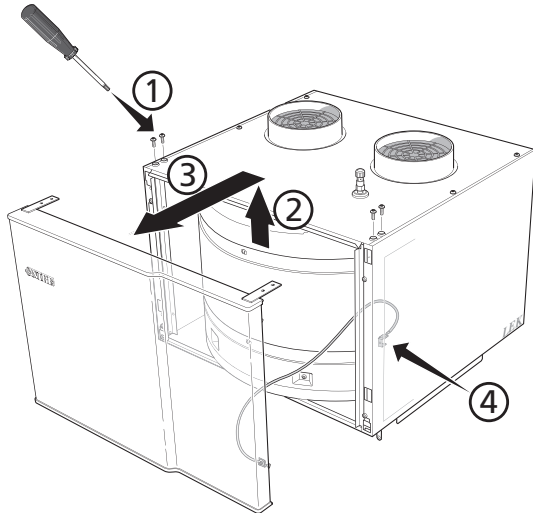

1. Slacken off the screws for the securing plate above F135.
2. Slide the hatch upwards and pull it towards you.
3. Pull the hatch towards yourself.

NOTE

A ground cable is installed in the hatch, it can therefore only be lifted out 0.35 m. If the hatch needs to be removed completely, the cable must be detached.

Side panels

1. Undo the screws at the edge.
2. Twist the cover slightly outward.
3. Move the side cover outwards and backwards.
4. Assembly takes place in the reverse order.

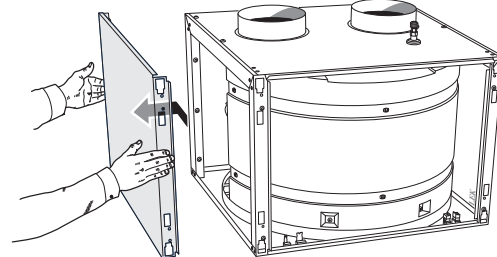
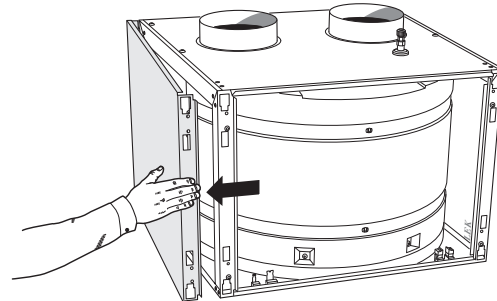
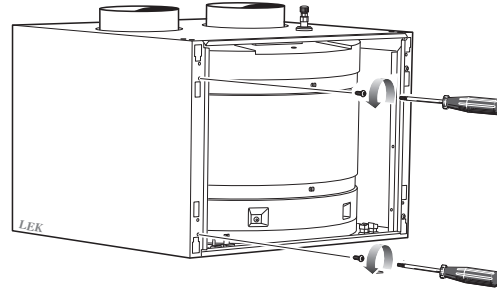

3 The exhaust air module design

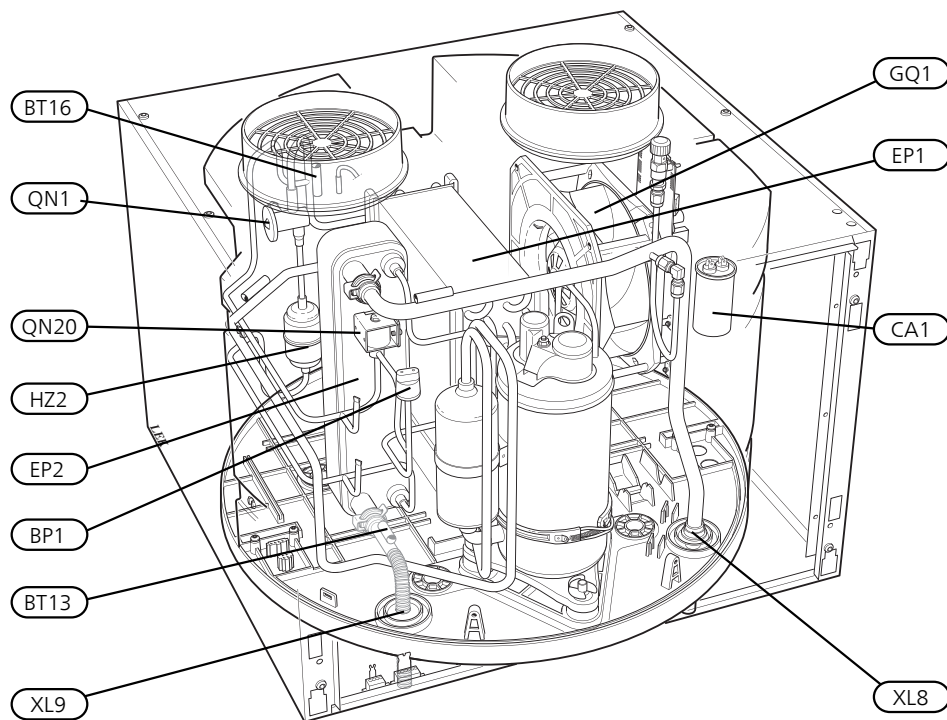
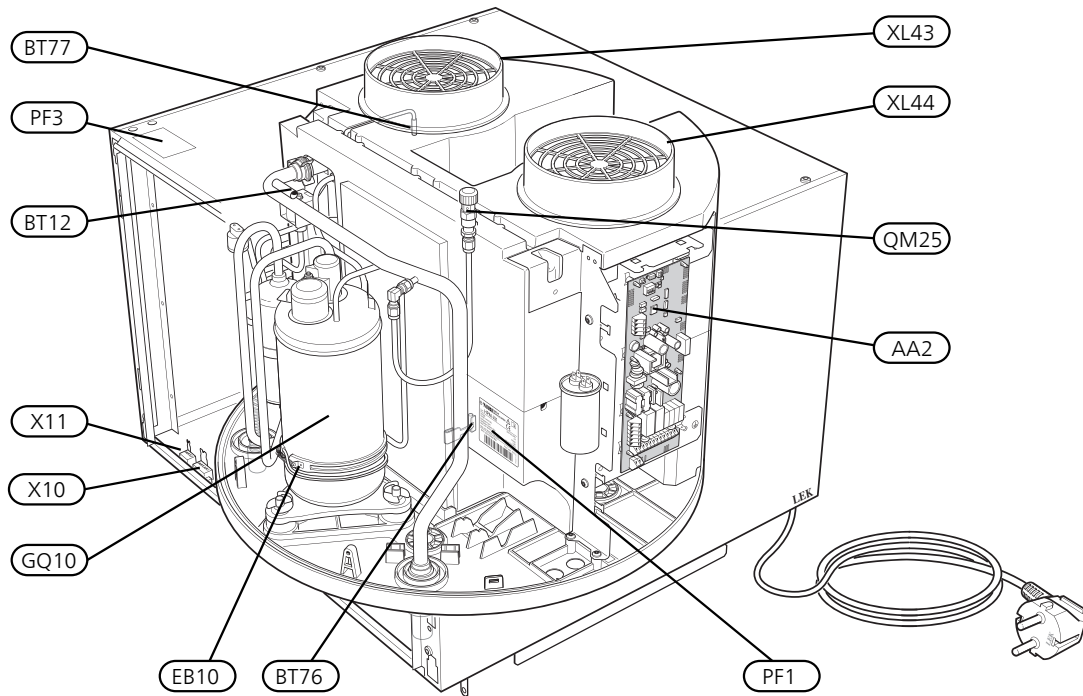

Pipe connections

XL8	Connection, heating medium supply line
XL9	Connection, return heating medium
XL43	Connecting incoming air
XL44	Connecting outgoing air
WM2	Overflow water discharge ¹

HVAC components

QM25	Venting, hot water
------	--------------------

Sensors etc.

BP1	High pressure pressostat
BT12	Temperature sensor, condenser out
BT13	Temperature sensor, heating medium return before condenser
BT16	Temperature sensor, evaporator
BT76	Temperature sensor, defrosting
BT77	Temperature sensor, incoming air

Electrical components

AA2	Base card
CA1	Capacitor
EB10	Compressor heater
X 10	PWM switch, circulation pump
X 11	Terminal block, communication indoor module

Cooling components

EP1	Evaporator
EP2	Condenser
GQ10	Compressor
HZ2	Drying filter
QN1	Expansion valve
QN20	Solenoid valve, defrosting

Ventilation

GQ1	Fan
HQ12	Air filter ¹

Miscellaneous

PF1	Rating plate
PF3	Serial number plate

¹Not visible in the image

Designations in component locations according to standard IEC 81346-1 and 81346-2.

4 Pipe and air connections

General pipe connections

Pipe installation must be carried out in accordance with current norms and directives.

F135 is only designed for upright installation. All connections are equipped with smooth pipe for compression ring couplings.

Overflow water from the evaporator's collecting trough is routed via the supplied plastic hose to a drain. Shape the hose into a water seal (see image).

The entire length of the overflow water pipe must be inclined to prevent water pockets and must also be frost-proof.

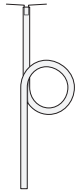

To make the installation economical, NIBE recommends that all pipes between F135 and the water heater are insulated. The insulation should be at least 12 mm thick.



NOTE

The pipe systems need to be flushed out before F135 is connected so that any debris cannot damage component parts.

Symbol key

Symbol	Meaning
	Venting valve
	Shut-off valve
	Non-return valve
	Shunt / shuttle valve
	Safety valve
	Temperature sensor
	Expansion vessel
	Circulation pump
	Particle filter
	Fan
	Compressor
	Radiator system
	Domestic hot water
	Under floor heating systems

System diagram

F135 is an exhaust air module.

When the air passes through the evaporator, the refrigerant evaporates because of its low boiling point. In this way the energy in the air is transferred to the refrigerant.

The refrigerant is then compressed in a compressor, causing the temperature to rise considerably.

The warm refrigerant is led to the condenser. Here the refrigerant gives off its energy to the hot water, whereupon the refrigerant changes state from gas to liquid.

The refrigerant then goes via filters to the expansion valve, where the pressure and temperature are reduced.

The refrigerant has now completed its circulation and returns to the evaporator.

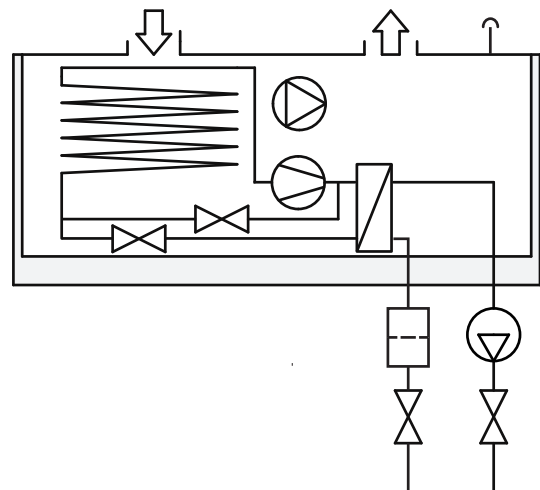

Dimensions and pipe connections

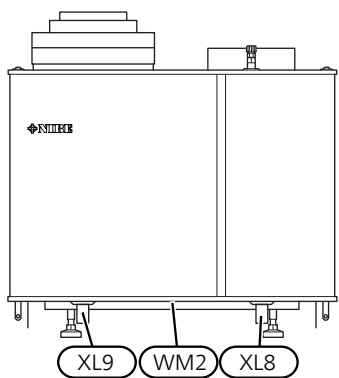
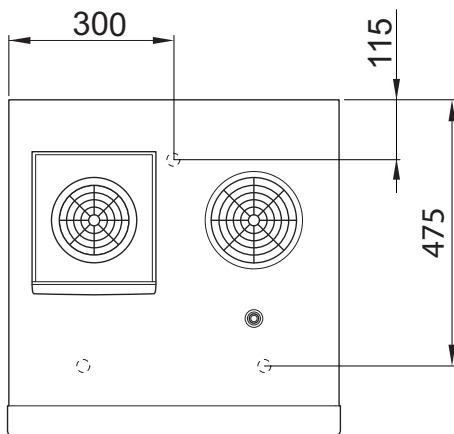
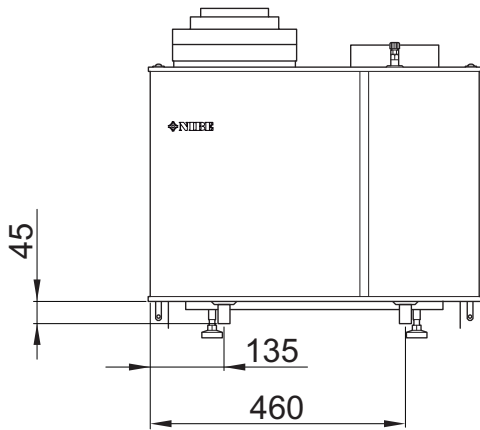

Pipe dimensions

Connection		
XL8 Heating medium out ext Ø	(mm)	22
XL9 Heating medium in ext Ø	(mm)	22
WM2 Overflow water discharge int Ø	(mm)	20

Mounting

The exhaust air module is wall-mounted using the brackets enclosed. The exhaust air module can also be placed on a suitable flat surface.



NOTE

Check that the mountings are located in the intended grooves on the exhaust air module.

Ensure that the exhaust air module is installed horizontally.

Installing on brackets

1. Install F135 on brackets.
2. Connect water and ventilation pipes.

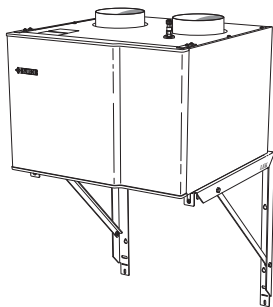
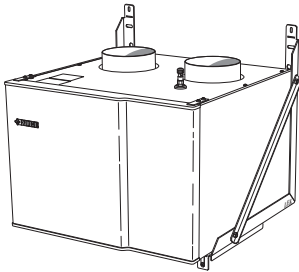

Installing brackets

1. Install the brackets together using the M6 screws and nuts supplied.
2. Drill holes in the wall as illustrated.
3. Fit the brackets on the wall.
4. Screw F135 into place in the brackets using the M5 screws and nuts supplied.

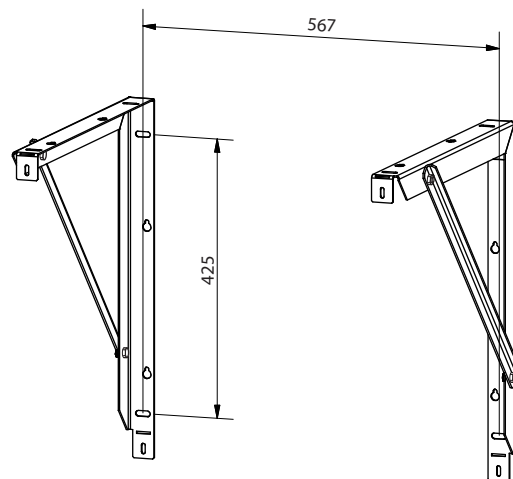
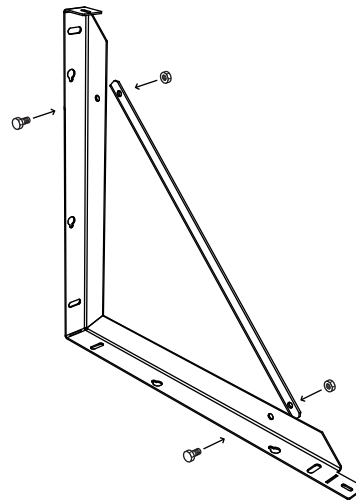

Connecting to indoor module and air-water heat pump

XL8 and XL9 are connected to the return line between the indoor module and the air-water heat pump. The particle filter must be installed before F135 to prevent dirt being deposited in F135. Install the shut-off valves outside F135 to facilitate any future servicing.

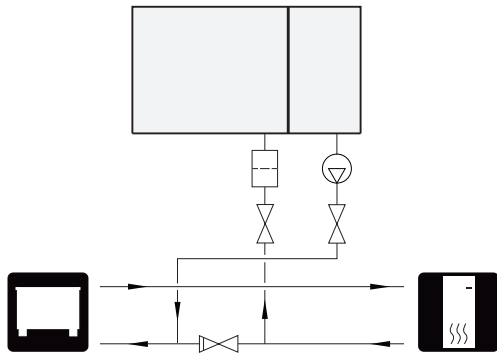

Installing choke washer

For optimal operation in VVM310/VVM500 install the enclosed choke washer.

Install the washer in the connection for supply line heating medium (XL8) before the installing the compression connection.

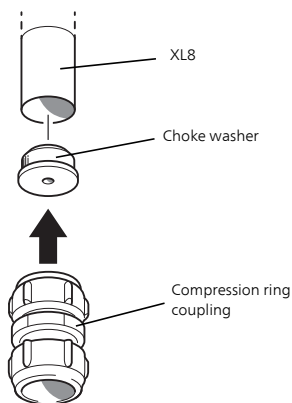

Installation exhaust air

F135 must be connected according to the instructions in this manual.

Installation must be carried out in accordance with current standards and directives.

Exhaust air

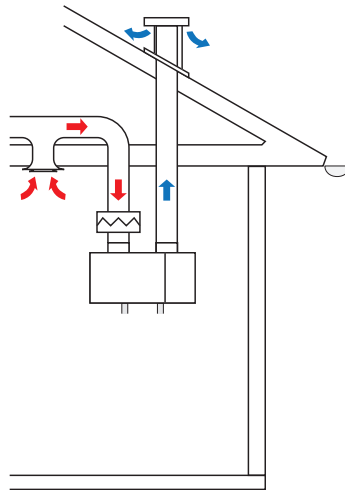

Connecting the exhaust air

The heat pump uses the heat that is in the building's ventilation air to heat the building and the hot water at the same time that the house is ventilated.

The hot air is transferred from the rooms to the heat pump via the exhaust air module.



NOTE

An air filter (HQ12) (enclosed), minimum classification G2, is required on the exhaust air duct of this connection. The filter must be cleaned regularly.



Caution

Noise from the fan can be transferred via the ventilation ducts.

Docking NIBE air-water heat pump

The demand on F135 is controlled by the indoor module in the system. The pump and fan speed are also controlled from the menu in the indoor module.

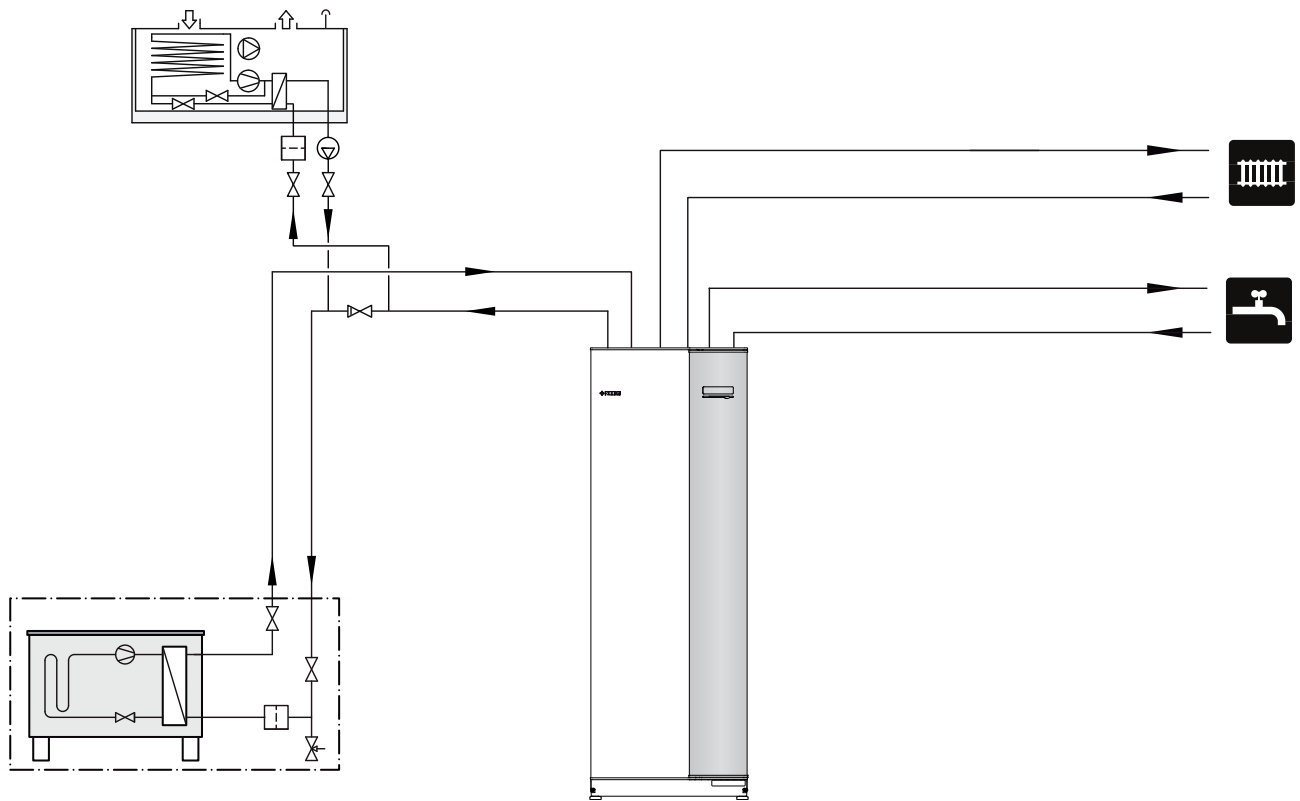

Docking NIBE F135, VVM, outdoor air, pool, cooling

F135 connected in air/water system with 4-pipe cooling. 4-pipe cooling must, in this instance, be connected between the outdoor air heat pump and F135. When there is also a pool, the F135 must be connected between 4-pipe cooling and the pool. The demand on F135 is controlled by the indoor module in the system. The pump and fan speed are also controlled from the menu in the indoor module.

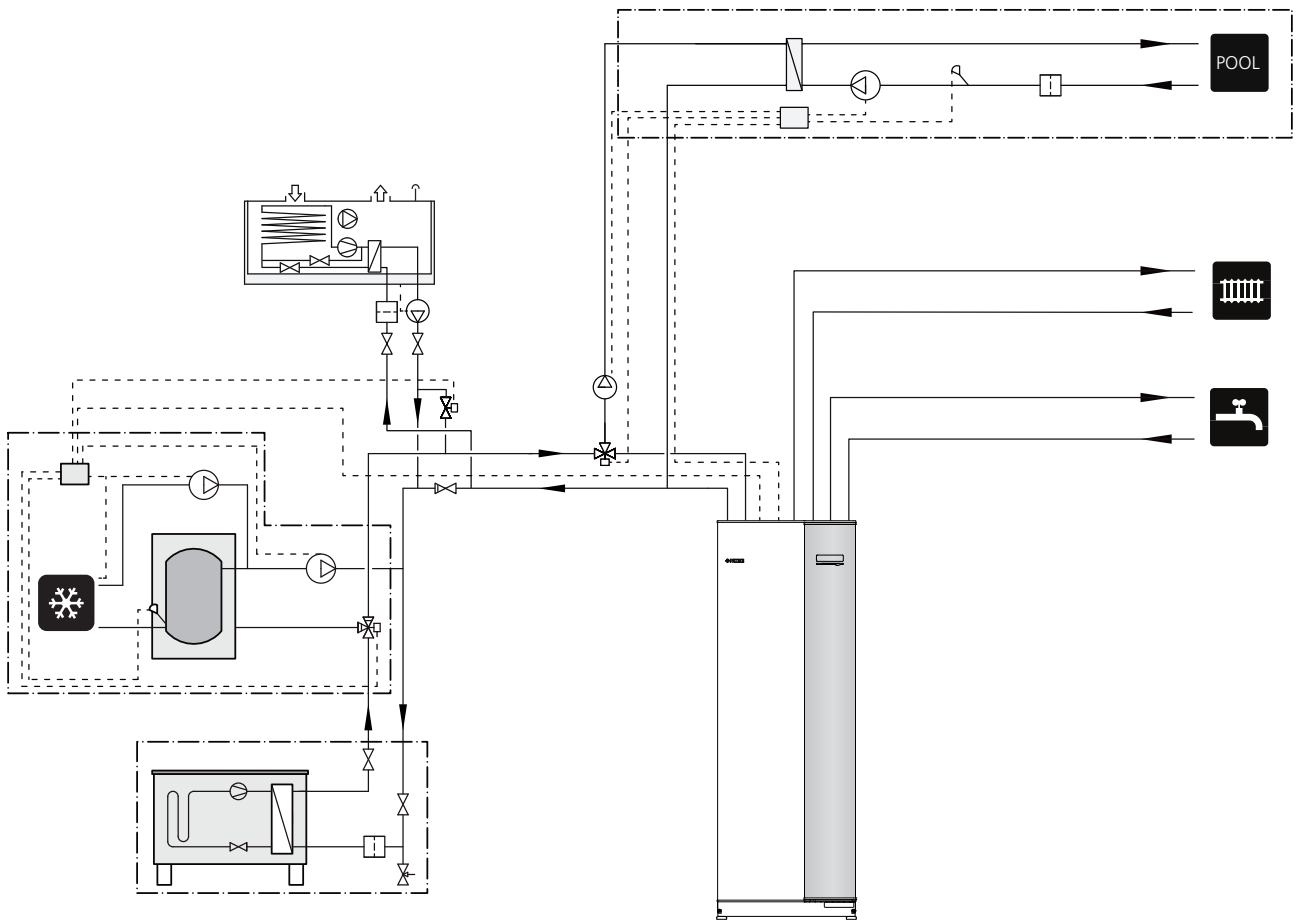

General ventilation connections

Ventilation installation must be carried out in accordance with current norms and directives.

To prevent fan noise being transferred via the air ducts, it may be a good idea to install a silencer in the ducts, alternatively mount the enclosed silencer in F135.

Connections must be made via flexible hoses, which must be installed so that they are easy to replace. Ducts that may become cold must be insulated with diffusion-proof material (PE30) along their entire lengths. Ensure that the condensation insulation is sealed at any joints and/or at lead-in nipples, silencers, roof cowls or similar. Provision must be made for inspection and cleaning of the duct. Make sure that there are no reductions in the cross-sectional area in the form of kinks, tight bends etc., since this will reduce the capacity. The air duct system must be a minimum of air tightness class B.

The exhaust air module must be fitted with an air filter.

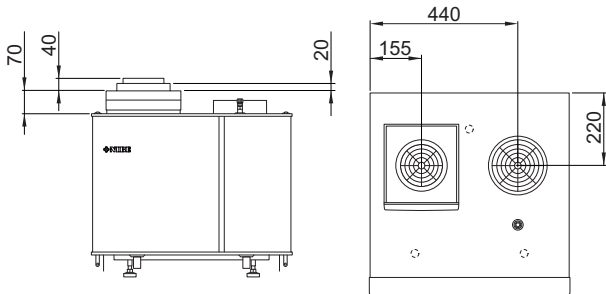
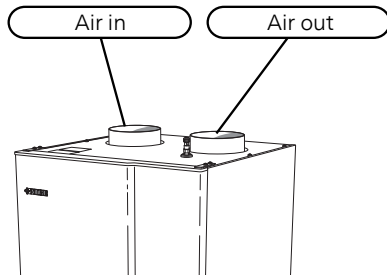

Install the filter cartridge

The filter cartridge has two sizes of connector, 125 mm or 160 mm.

1. Check the diameter of the air channel for inlet air.
2. When the air duct has a large diameter (\varnothing 160 mm) the inner ring must be cut out of the upper section of the filter cartridge.
3. Cut just inside the inner edge of the outer ring using a sharp knife. The plastic is prepared for easy cutting.
4. Press the filter cartridge into place in the connection for incoming air (XL43).

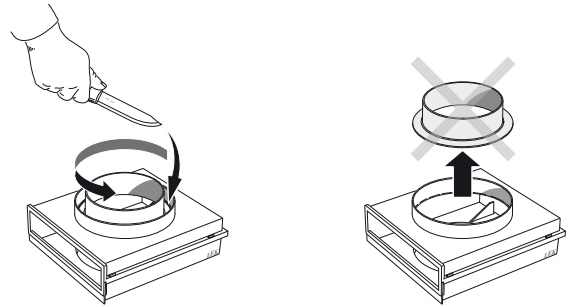

Install the connector

If a filter solution other than that enclosed is used, the enclosed coupling must be mounted in the connection for incoming air (XL43).

Install the silencer

1. Remove the plugs from the silencer enclosed.
2. Install the silencer in the connector for outgoing air (XL44).

Exhaust air duct /kitchen fan

Exhaust air duct (kitchen fan) must not be connected to F135.

To prevent food vapour being transferred to F135 the distance between the kitchen fan and the exhaust air device must be considered. The distance should not be less than 1.5 m, but this can vary between different installations.

Always use a kitchen fan when cooking.



NOTE

A duct in a masonry chimney stack must not be used for extract air.

Ventilation flow (exhaust air)

Connect F135 so that all exhaust air except exhaust air duct air (kitchen fan) passes the heat exchanger (EP1) in the exhaust air module. Lowest ventilation flow must comply with applicable standards. For optimum exhaust air module performance the ventilation flow should not be less than 25 l/s (90 m³/h). On occasions when the exhaust air temperatures are lower than 20 °C (for example on start-up and when there is no one at home) the minimum value is 31 l/s (110 m³/h).

Ensure that the ventilation openings are not blocked. If the exhaust air module is connected to the indoor module, set the ventilation capacity in the menu system (menu 5.1.5). Otherwise the ventilation capacity is set via potentiometer (AA5-SF3).

Adjusting ventilation (exhaust air)

To obtain the necessary air exchange in every room of the house, the exhaust air devices must be correctly positioned and adjusted and the fan in the exhaust air module adjusted.

Immediately after installation adjust the ventilation so that it is set according to the projected value of the house.

A defective ventilation installation may lead to reduced installation efficiency and thus poorer operating economy, and may result in moisture damage to the house.

5 Electrical connections

General

Installation must be carried out in accordance with current standards and directives.

When working behind screwed covers, the circuit fuse must be removed or the connection plug pulled out.

Work behind screwed covers may only be carried out under the supervision of a qualified electrician.

- Disconnect F135 before insulation testing the house wiring.
- For electrical wiring diagram for F135, see page 33.
- Signal cables to external connections must not be laid close to high current cables.
- Signal cables to external connections are four core, at least 0.35 mm².
- If the supply cable is damaged, it must be replaced by qualified persons.

NOTE

The supply cable must not be connected until the boiler has been filled. Internal components can be damaged.

NOTE

Electrical installation and service must be carried out under the supervision of a qualified electrician. Electrical installation and wiring must be carried out in accordance with the stipulations in force.

Connections

Power connection

NOTE

To prevent interference, unshielded communication and/or sensor cables to external connections must not be laid closer than 20 cm from high voltage cables.

F135 is connected to an earthed socket with the factory installed power cord, which is supplied with connection plug. The power connection to the circulation pump must be connected via a circuit breaker with a minimum breaking gap of 3 mm.

NOTE

The circulation pump must not be powered up until F135 is activated in the indoor module.

Indoor module

Connect the indoor module input board (AA3-X4) to the four-pole terminal block X11:1 (15), X11:2 (14) and X11:3 (13).

Connect the circulation pump's communication cable to the six pin terminal block in F135 X10:1 (Blue), X10:2 (Brown) and X10:6 (Black).

Use a 3 core cable of at least 0.5 mm² cable area.



NOTE

Cable between the indoor module and F135 must be a max of 15 m.

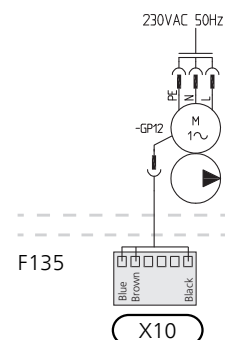
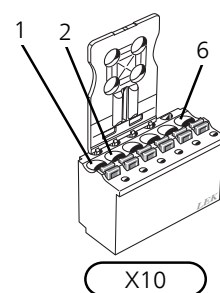
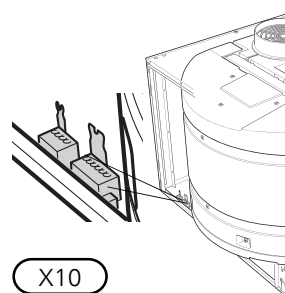
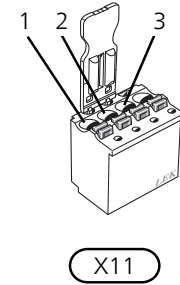
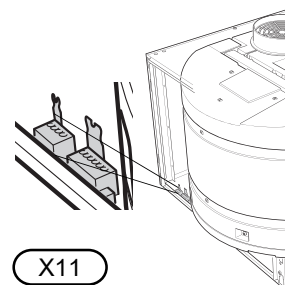
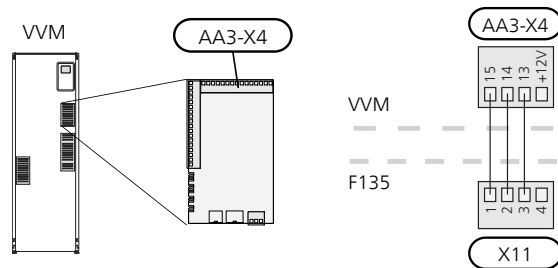

Optional connections

AUX inputs

Switch for external blocking of compressor

When external blocking of the compressor is desired, this can be connected to terminal block X13 on the base board (AA2).

The compressor is disconnected by connecting a potential-free switch function to AUX2 (X13:3 och X13:4) (compressor).

A closed contact results in the electrical output being disconnected.

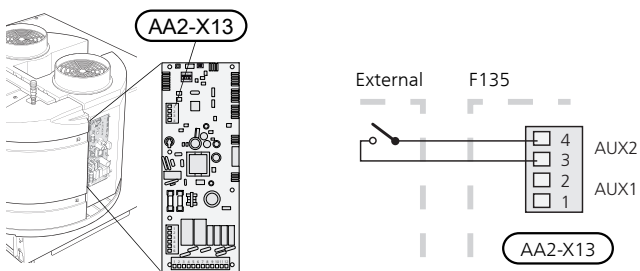

Connecting shut-off valve (QN44)

Connect the motor (QN44) to AA5-X9:2 (signal), AA5-X9:1 (N) and AA5-X10:2 (230 V).

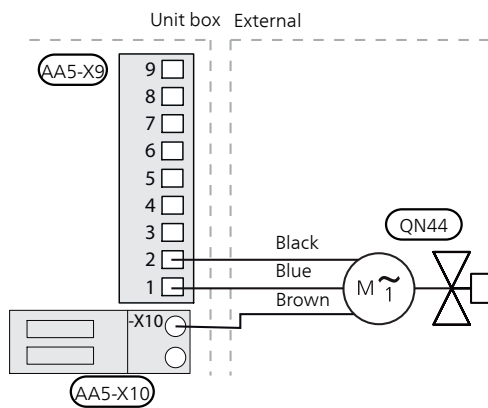

6 Commissioning and adjusting

Preparations

1. Check that the switch for the indoor module is in position "⏻".
2. Cut the power to F135.
3. Check that the filling valves are fully closed.

Filling and venting



Caution

Insufficient venting can damage internal components in F135.

Filling the climate system

1. Check that the externally mounted shut-off valves for the heating system are open.
2. Open the vent valve (QM25).
3. Open the externally mounted filler valves. F135 and the rest of the climate system are filled with water.
4. When the water that exits the vent valve (QM25) is not mixed with air, close the valve. After a while, the pressure rises on the external pressure gauge. When the pressure reaches 2.5 bar (0.25 MPa) the safety valve starts to release water. Close the external filler valve.
5. Reduce the boiler pressure to the normal working range (approx. 1 bar) by opening the vent valve (QM25) or the external safety valve.

Venting the climate system



NOTE

Venting may be necessary during installation and after a period of use.

1. Cut the power to the exhaust air module.
2. Vent the exhaust air module via the vent valve (QM25) and the rest of the climate system via the relevant vent valves.
3. Keep topping up and venting until all air has been removed and the pressure is correct.

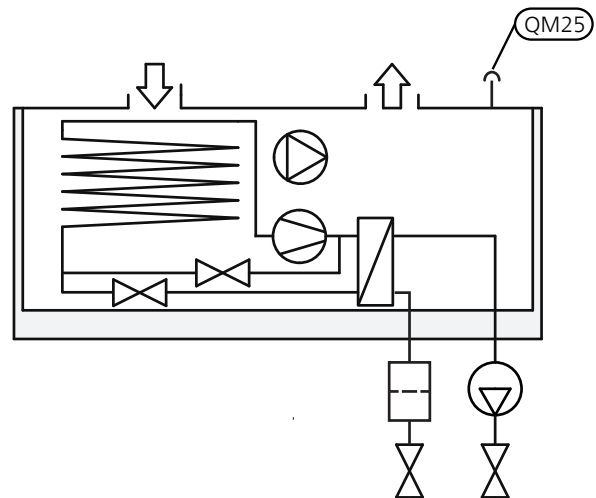

Start-up and inspection

Start-up with NIBE Indoor module

**NOTE**

There must be water in the climate system before the switch in the indoor module is set to "I".

**NOTE**

The circulation pump must not be powered up until F135 is activated in the indoor module.

1. Start F135 by connecting the supply cable.
2. Set the indoor module's switch to "I".
3. Follow the instructions in the start guide in the indoor module display. If the start guide does not start when you start the indoor module, start it manually in menu 5.7.

Commissioning with NIBE Indoor module

The first time that the indoor module is started, a start guide begins. The start guide instructions state what needs to be carried out at initial start-up together with a run through of the indoor module's basic settings.

The start guide ensures that the start-up is carried out correctly and cannot be bypassed. The start guide can be started later in menu 5.7.

The circulation pump operates at a fixed speed. Can be changed in menu 5.3.14.

**Caution**

As long as the start guide is active, no function in the installation will start automatically.

The guide will appear at each installation restart until it is deselected on the last page.

Setting ventilation (exhaust air)

Ventilation must be set according to applicable standards. Set the fan speed in menu 5.1.5.

Even if ventilation is roughly set at installation it is important that a ventilation adjustment is ordered and permitted.



NOTE

Order a ventilation adjustment to complete the setting.

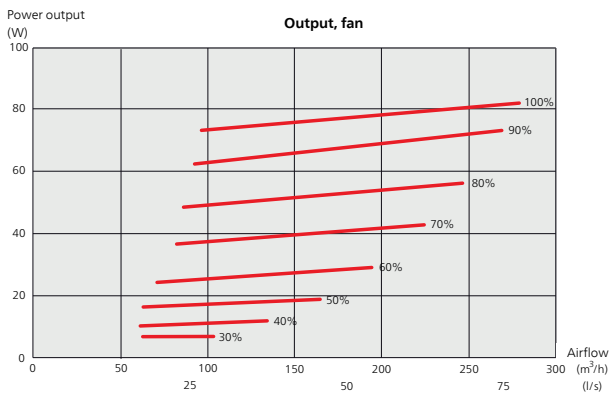
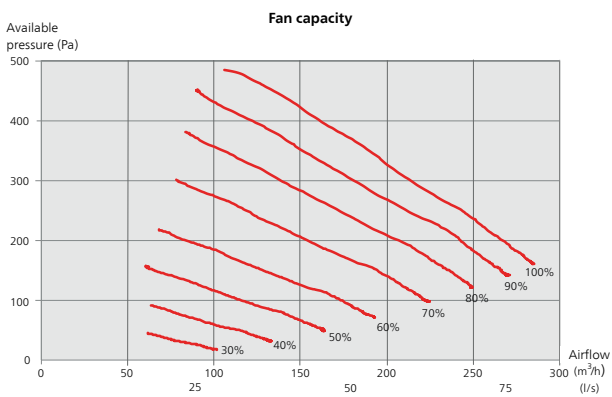

7 Disturbances in comfort

In most cases, the indoor module notes a malfunction (malfunctions can lead to disruption in hot water comfort) and indicates this with alarms in the display.

Info menu indoor module

All the indoor module measured values are gathered under menu 3.1 in the indoor module menu system. Looking through the values in this menu can often simplify finding the source of the fault.

Manage alarm (NIBE Indoor module)

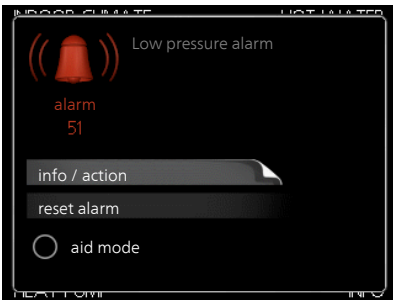

In the event of an alarm, some kind of malfunction has occurred, which is indicated by the status lamp changing from green continuously to red continuously. In addition, an alarm bell appears in the information window.

Alarm

In the event of an alarm with a red status lamp a malfunction has occurred that the indoor module cannot remedy itself. In the display, by turning the control knob and pressing the OK button, you can see the type of alarm it is and reset it. You can also choose to set the indoor module to aid mode.

info / action Here you can read what the alarm means and receive tips on what you can do to correct the problem that caused the alarm.

reset alarm In most cases it is enough to select "reset alarm" to correct the problem that caused the alarm. If a green light illuminates after selecting "reset alarm" the alarm has been remedied. If a red light is still visible and a menu called "alarm" is visible in the display, the problem that caused the alarm remains. If the alarm disappears and then returns, see the troubleshooting section (page 25).

aid mode "aid mode" is a type of emergency mode. This means that the indoor module produces heat and/or hot water, even though there is some kind of problem with the indoor module.

Problems with F135 do not affect the indoor module's operation. You do not need to select "aid mode" in event of problems with F135.



Caution

Selecting "aid mode" is not the same as correcting the problem that caused the alarm. The status lamp will therefore continue to be red.

Troubleshooting

If the malfunction does not appear in the display, or F135 is not connected to the indoor module, the following tips can be used:

Basic actions

Start by checking the following possible fault sources:

- That the feed cable is connected to F135.
- Group and main fuses of the accommodation.
- The property's earth circuit breaker.

Low or a lack of ventilation (exhaust air installation)

- Filter (HQ12) blocked.
 - Clean or replace the filter.
- The ventilation is not adjusted.
 - Order/implement ventilation adjustment.
- Exhaust air device blocked or throttled down too much.
 - Check and clean the exhaust air devices.
- Fan speed in reduced mode.
 - Enter menu 1 and select "normal".

High or distracting ventilation (exhaust air installation)

- Filter (HQ12) blocked.
 - Clean or replace the filter.
- The ventilation is not adjusted.
 - Order/implement ventilation adjustment.
- Fan speed in forced mode.
 - Enter menu 1 and select "normal".



NOTE

To select aid mode an alarm action must be selected in the menu 5.1.4.

Gurgling sound

- Not enough water in the water seal.
 - Refill the water seal with water.
- Choked water seal.
 - Check and adjust the condensation water hose.

8 Accessories

Top cabinet

Top cabinet that conceals the ventilation ducts.

245 mm

Part no. 089 756

345 mm

Part no. 089 757

445 mm

Part no. 067 522

385-635 mm

Part no. 089 758

9 Technical data

Dimensions and setting-out coordinates

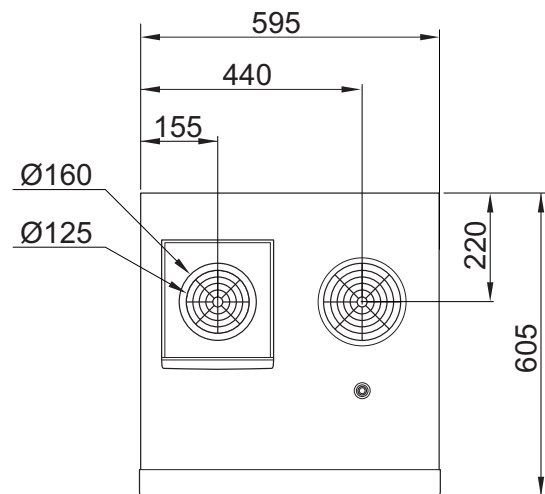
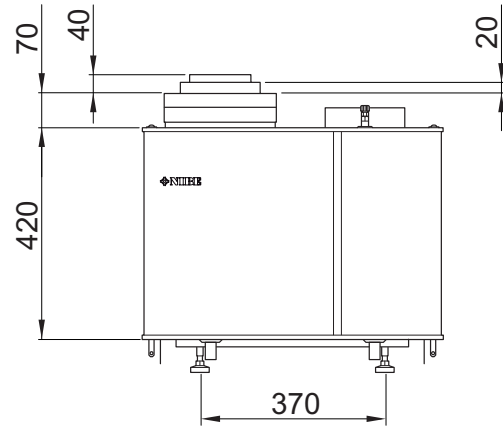
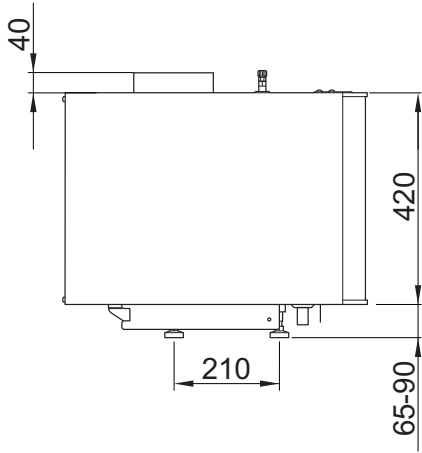

Technical specifications

1x230 V		
Output data according to EN 14 511		
Specified heating output (P _H) ¹	kW	1.42
COP ¹		3.87
Specified heating output (P _H) ²	kW	1.34
COP ²		3.13
Specified heating output (P _H) ³	kW	1.27
COP ³		2.65
Electrical data		
Rated voltage	V	230V ~ 50 Hz
Max operating current	A	3.5
Driving power circulation pump	W	5 - 20
Driving power fan	W	20 - 75
Specified compressor output according to EN16147 ⁶	kW	1.32
Min fuse rating	A	6
Enclosure class		IP 21
Refrigerant circuit		
Type of refrigerant		R134A
Volume	kg	0.38
Compressor type		Rotation
Cut-out value pressostat HP	MPa/bar	2.2/22.0
Exhaust air module		
Max system pressure	MPa/bar	1.0/10
Max supply temperature	°C	63
Max return temperature	°C	54
Energy class circulation pump		low energy
Air flow requirement		
Min air flow, air temperature >10 °C	l/s	25
Temperature range for compressor operation	°C	+10 - +37
Sound effect level according to EN 12 102		
Sound power level (L _{W(A)}) ⁴	dB(A)	47
Sound pressure levels according to EN ISO 11 203		
Sound pressure level in boiler room (L _{P(A)}) ⁵	dB(A)	43
Pipe connections		
Heating medium, supply ext Ø	mm	22
Heating medium, return ext Ø	mm	22
Ventilation ext Ø	mm	160
Filter box ext Ø	mm	160 / 125

¹A20(12)W35, exhaust air flow 180 m³/h (50 l/s) excl. driving power for fan

²A20(12)W45, exhaust air flow 180 m³/h (50 l/s) excl. driving power for fan

³A20(12)W55, exhaust air flow 180 m³/h (50 l/s) excl. driving power for fan

⁴The value varies with the selected fan speed. Visit www.nibe.eu for more detailed acoustic data, including sound to ducts

⁵The value can vary with the room's damping capacity. These values apply with 4 dB of damping

⁶180 m³/h

Miscellaneous		
Dimensions and weight		
Width	mm	600
Depth	mm	605
Height (excluding connectors)	mm	490 - 515
Weight	kg	50
Part No.		066 075

Energy labelling

Information sheet

Supplier		NIBE
Model		F135
Temperature application	°C	35 / 55
Seasonal space heating energy efficiency class, average climate		A+ / A+
Rated heat output (P _{designh}), average climate	kW	2
Annual energy consumption space heating, average climate	kWh	879 / 1087
Seasonal space heating energy efficiency, average climate	%	141 / 114
Sound power level L _{WA} indoors	dB	47
Rated heat output (P _{designh}), cold climate	kW	2
Rated heat output (P _{designh}), warm climate	kW	2
Annual energy consumption space heating, cold climate	kWh	1004 / 1264
Annual energy consumption space heating, warm climate	kWh	587 / 731
Seasonal space heating energy efficiency, cold climate	%	147 / 117
Seasonal space heating energy efficiency, warm climate	%	136 / 110
Sound power level L _{WA} outdoors	dB	-

Technical documentation

Model				F135							
Type of heat pump				<input type="checkbox"/> Air-water <input checked="" type="checkbox"/> Exhaust-water <input type="checkbox"/> Brine-water <input type="checkbox"/> Water-water							
Low-temperature heat pump				<input type="checkbox"/> Yes <input checked="" type="checkbox"/> No							
Integrated immersion heater for additional heat				<input type="checkbox"/> Yes <input checked="" type="checkbox"/> No							
Heat pump combination heater				<input type="checkbox"/> Yes <input checked="" type="checkbox"/> No							
Climate				<input checked="" type="checkbox"/> Average <input type="checkbox"/> Cold <input type="checkbox"/> Warm							
Temperature application				<input checked="" type="checkbox"/> Average (55 °C) <input type="checkbox"/> Low (35 °C)							
Applied standards				EN14825 EN16147							
Rated heat output		Prated	1,5	kW	Seasonal space heating energy efficiency		η_s	114	%		
<i>Declared capacity for space heating at part load and at outdoor temperature T_j</i>				<i>Declared coefficient of performance for space heating at part load and at outdoor temperature T_j</i>							
$T_j = -7\text{ °C}$	Pdh	1.3	kW	$T_j = -7\text{ °C}$	COPd	3.0	-				
$T_j = +2\text{ °C}$	Pdh	1.3	kW	$T_j = +2\text{ °C}$	COPd	3.1	-				
$T_j = +7\text{ °C}$	Pdh	1.3	kW	$T_j = +7\text{ °C}$	COPd	3.3	-				
$T_j = +12\text{ °C}$	Pdh	1.4	kW	$T_j = +12\text{ °C}$	COPd	3.3	-				
$T_j = \text{biv}$	Pdh	1.2	kW	$T_j = \text{biv}$	COPd	2.7	-				
$T_j = \text{TOL}$	Pdh	1.2	kW	$T_j = \text{TOL}$	COPd	2.8	-				
$T_j = -15\text{ °C}$ (if TOL < -20 °C)	Pdh		kW	$T_j = -15\text{ °C}$ (if TOL < -20 °C)	COPd		-				
Bivalent temperature				T_{biv}	-6.9	°C	Min. outdoor air temperature		TOL	-10	°C
Cycling interval capacity				P _{ych}		kW	Cycling interval efficiency		COP _{yc}		-
Degradation coefficient				Cdh	0.98	-	Max supply temperature		WTOL	58	°C
<i>Power consumption in modes other than active mode</i>				<i>Additional heat</i>							
Off mode		P _{OFF}	0.003	kW	Rated heat output		P _{sup}	0.3	kW		
Thermostat-off mode		P _{TO}	0.01	kW							
Standby mode		P _{SB}	0.005	kW	Type of energy input		Electric				
Crankcase heater mode		P _{CK}	0.01	kW							
<i>Other items</i>											
Capacity control		Fixed		Rated airflow (air-water)			150	m ³ /h			
Sound power level, indoors/outdoors		L _{WA}	47 / -	dB	Nominal heating medium flow			0.13	m ³ /h		
Annual energy consumption		Q _{HE}	1,087	kWh	Brine flow brine-water or water-water heat pumps				m ³ /h		

Electrical circuit diagram

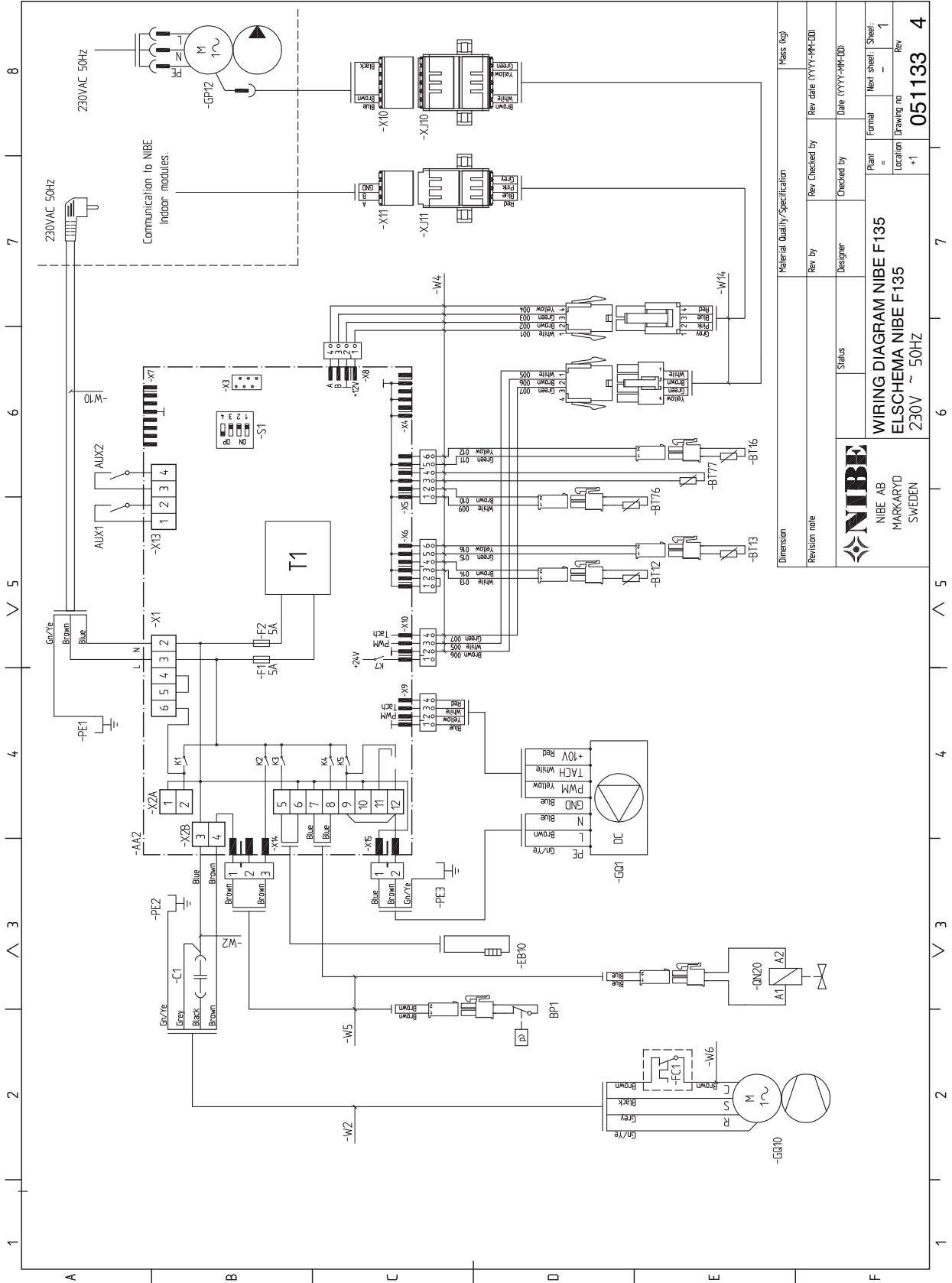

Dimension	Material Quality/Specification	Mass (kg)
Revision note	Rev. by	Rev. date (YYYY-MM-DD)
	Designer	Checked by
	Status	Date (YYYY-MM-DD)
	Plant =	Formal
	Location	Next sheet Sheet:
	+1	Drawing no
		Rev
		051133
		4



WIRING DIAGRAM NIBE F135
ELSCHEMA NIBE F135
 230V ~ 50HZ

NIBE AB
 MARKARYD
 SWEDEN

10 Item register

Item register

A

- Accessories, 27
- Adjusting ventilation, 19
- Assembly, 7

C

- Commissioning and adjusting, 22
 - Filling and venting, 22
 - Preparations, 22
 - Start-up and inspection, 23
- Connecting cold and hot water, 15
- Connecting the climate system, 15
- Contact information, 6

D

- Delivery and handling, 7
 - Removing the covers, 9
 - Supplied components, 8
 - Transport, 7
- Dimensions and pipe connections, 13, 15
- Dimensions and setting-out coordinates, 28
- Disturbances in comfort
 - Manage alarm, 25
 - Troubleshooting, 25

E

- Electrical circuit diagram, 33
- Electrical connections, 20
 - Connections, 20
 - General, 20
- Energy labelling, 31
 - Information sheet, 31
 - Technical documentation, 32
- Exhaust air duct, 19
- External connection options
 - Possible selection for AUX inputs, 21
 - Switch for external blocking of compressor, 21

F

- Filling and venting, 22
 - Filling the hot water heater, 22
- Filling the hot water heater, 22

I

- Important information, 4
 - Recovery, 4
 - Safety information, 4
- Inspection of the installation, 5

M

- Manage alarm, 25
- Marking, 4
- Mounting
 - Installation/Suspension, 14

P

- Pipe and air connections, 12
- Pipe and ventilation connections
 - Adjusting ventilation, 19
 - Connecting cold and hot water, 15
 - Connecting the climate system, 15
 - Dimensions and pipe connections, 13, 15
 - Exhaust air duct, 19
 - General pipe connections, 12
 - Pipe dimensions, 13
 - Symbol key, 12
 - System diagram, 12
 - Ventilation flow, 19
- Pipe dimensions, 13
- Possible selection for AUX inputs, 21

- Preparations, 22

R

- Removing the covers, 9

S

- Safety information, 4
 - Contact information, 6
 - Inspection of the installation, 5
 - Marking, 4
 - Serial number, 4
 - Symbols, 4
- Serial number, 4
- Start-up and inspection, 23
 - Setting the ventilation, 24
 - Start-up with NIBE Indoor module, 23
- Supplied components, 8
- Switch for external blocking of compressor, 21
- Symbol key, 12
- Symbols, 4
- System diagram, 12

T

- Technical data, 28
 - Dimensions and setting-out coordinates, 28
 - Electrical circuit diagram, 33
 - Technical Data, 29
- Technical Data, 29
- The design of the exhaust air module, 10
 - List of components, 11
- Transport, 7
 - Assembly, 7
- Troubleshooting, 25

V

- Ventilation flow, 19

NIBE AB Sweden
Hannabadsvägen 5
Box 14
SE-285 21 Markaryd
info@nibe.se
www.nibe.eu



331432